



ACCESSORI IN ALLUMINIO  
PER SERRAMENTI, RINGHIERE,  
BALCONI E SCALE



## **SISTEMI DI ANCORAGGIO PER PARAPETTI IN VETRO**

*ANCHORING SYSTEMS  
FOR GLASS PARAPETS*

**SOLUZIONI PER PARAPETTI,  
BALCONI, SCALE, PENSILINE,  
DIVISORI E PISCINE**

*DEVELOPED FOR:  
BALUSTRADES, BALCONIES,  
STAIRS CANOPIES, DIVIDERS  
AND SWIMMING POOLS*

**PROFILI | ACCESSORI  
ISTRUZIONI  
CERTIFICAZIONI**

*PROFILES | ACCESSORIES  
TUTORIALS | TEST REPORTS*



## **TOTAL GLASS SPEEDY È IL SISTEMA BREVETTATO N° 102021000015161 DI PROFILI IN BARRA PIÙ PERFORMANTE DI COMPAS**

- Massima velocità di installazione mediante cunei registrabili con un semplice avvitatore dall'interno
- Massima resistenza ai carichi di spinta, certificazioni UNI11678 per edilizia pubblica e residenziale
- Facilità di montaggio del sistema senza l'ausilio di ponteggi esterni
- Regolazione e manutenzione facilitata anche dopo la posa
- Predisposto per l'illuminazione del cristallo mediante led
- Disponibili corrimani e profili scarico acque piovane

## **TOTAL GLASS SPEEDY IS COMPAS'S PATENTED MOST PERFORMING BAR PROFILE SYSTEM**

- *Installation speed maximized by means of adjustable wedges*
- *Improved resistance to static loads, UNI11678 certifications for public and residential buildings*
- *Easy assembly of the system without the aid of external scaffolding*
- *Easy adjustment and maintenance even after laying*
- *Ready to mount led strips for glass lighting*
- *Handrails and rainwater discharge profiles available as optional accessories*



# TOTAL GLASS

**TOTAL GLASS È UN SISTEMA BREVETTATO N° MI2014A001804 DI ANCORAGGIO PER PARAPETTI IN CRISTALLO UNICO ED INNOVATIVO PROGETTATO PER RISPONDERE ALLE ATTUALI RICHIESTE DI SICUREZZA, DI FACILE MONTAGGIO E MANUTENZIONE.**

- Certificato per edificio pubblico fino a 300 Kg e per edificio privato fino a 200 Kg per metro lineare
- Facilità di montaggio senza l'ausilio di ponteggi esterni
- Nuovo sistema di scarico delle acque senza interruzione del cristallo
- Regolazione e manutenzione facilitata anche dopo la posa
- Predisposto per l'illuminazione del cristallo mediante LED
- Grazie alla vasta gamma di soluzioni quali: a pavimento, sopra muretto fronte soletta balcone, pensilina, lato gradino per scale, a scomparsa, il sistema TOTAL GLASS può essere personalizzato per rispondere ad ogni esigenza

**TOTAL GLASS IS AN UNIQUE, INNOVATIVE, AND PATENTED CRYSTAL PARAPET ANCHORAGE SYSTEM, DESIGNED TO MEET THE CURRENT DEMANDS FOR SAFETY, EASE OF ASSEMBLY, AND MAINTENANCE.**

- *Certified for public building up to 300 Kg per linear meter and for private building up to 200 Kg per linear meter*
- *Easy of assembly without the use of external scaffoldings*
- *New water discharge system without crystal interruption*
- *Easy adjustment and maintenance even after laying*
- *Fitted for crystal lighting by means of LEDs*
- *Thanks to the wide range of solutions like: floor, over wall balcony front base, canopy, side step for stairs, hidden, the TOTAL GLASS system can be customized to meet all needs*



# INDICE PRODOTTI | INDEX OF PRODUCTS

## CUNEI

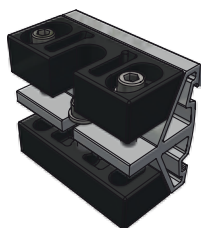

CUNEI PER FISSAGGIO DEL VETRO ALL'INTERNO DEI PROFILI

*GLASS FIXING WEDGES*

PAG. 5

## TGS 50



SOLUZIONE A BARRA INTERA DA 3000 O 6000 mm  
INSTALLAZIONE SOPRA MURETTO, PER VETRO  
5+1.52+5/6+1.52+6

*BAR PROFILES, 3000 OR 6000 mm LENGTH ABOVE  
WALL INSTALLATION, FOR 5+1.52+5/6+1.52+6 GLASS*

PAG. 8

## TGS 100



SOLUZIONE A BARRA INTERA DA 3000 O 6000 mm  
CON CUNEI

*BAR PROFILE, 3000 OR 6000 mm LENGTH, WITH  
WEDGES*

PAG. 10

## TGS 200



SOLUZIONE A BARRA INTERA DA 3000 O 6000 mm  
CON CUNEI

*BAR PROFILE, 3000 OR 6000 mm LENGTH,  
WITH WEDGES*

PAG. 13

## TGS 300



SOLUZIONE A SCOMPARSA BARRA INTERA  
DA 3000 O 6000 mm CON CUNEI

*BAR PROFILE, 3000 OR 6000 mm  
HIDDEN SOLUTION WITH WEDGES*

PAG. 16

## TGS 400



SOLUZIONE A BARRA INTERA DA 3000 O 6000 mm  
CON CUNEI

*BAR PROFILE, 3000 OR 6000 mm LENGTH,  
WITH WEDGES*

PAG. 19

# INDICE PRODOTTI | INDEX OF PRODUCTS

## TGS 500



PENSILINA, SOLUZIONE A BARRA INTERA DA 3000 O 6000 mm, CON CUNEI

*CANOPY, 3000 OR 6000 mm LENGTH, WITH WEDGES*

PAG. 23

## TGS 600

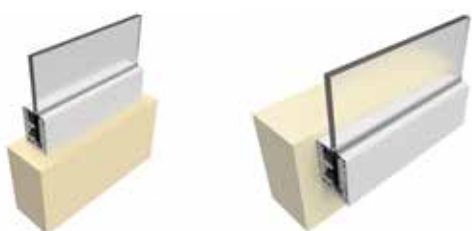

SOLUZIONE A BARRA INTERA DA 3000 O 6000 mm CON CUNEI

CERTIFICATO PER L'EDILIZIA PUBBLICA

*BAR PROFILE, 3000 OR 6000 mm LENGTH, WITH WEDGES*

*TESTED FOR PUBLIC BUILDINGS*

PAG. 27

## TGS 700

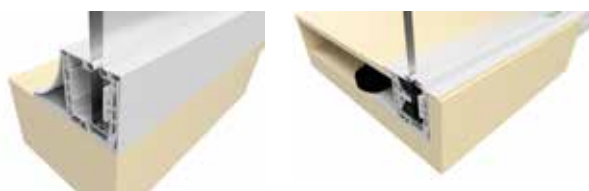

SOLUZIONE A BARRA INTERA DA 3000 O 6000mm INSTALLAZIONE A FILO SOLETTA O INCASSO CON CUNEI

*BAR PROFILE, 3000 OR 6000 mm LENGHT FOR SLAB/EMBEDDING THREAD, WITH WEDGES*

PAG. 30

## TG 300



PRIMA

SOLUZIONE A BLOCCHETTI PER FISSAGGIO A PAVIMENTO

CON CARTER PER CHIUSURA

*BLOCKS SOLUTION FOR FLOOR FIXING WITH COVERING PROFILE*



DOPO

PAG. 34

## TG 400



PRIMA

SOLUZIONE A BLOCCHETTI PER FISSAGGIO FRONTE SOLETTA

CON CARTER PER CHIUSURA

*BLOCKS SOLUTION FOR FRONT WALL FIXING WITH COVERING PROFILE*



DOPO

PAG. 41

# INDICE PRODOTTI | INDEX OF PRODUCTS

## TG 800R



SOLUZIONE A BARRA INTERA DA 3000 O 6000 mm FISSAGGIO FRONTE SOLETTA CERTIFICATO PER L'EDILIZIA PUBBLICA

*BAR PROFILE, 3000 OR 6000 mm LENGTH  
FRONT WALL FIXING  
TESTED FOR PUBLIC BUILDINGS*

PAG. 48

## TG 1000



SOLUZIONE A BARRA INTERA DA 3000 O 6000 mm

*BAR PROFILE, 3000 OR 6000 mm LENGTH*

PAG. 52

## ACCESSORI VARI

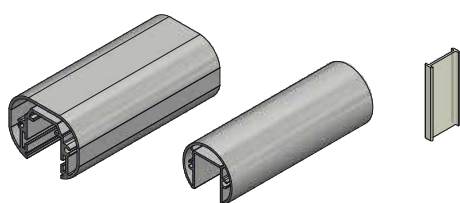

GUARNIZIONI, PROFILATI, SUPPORTI E ALTRO

*GASKETS, PROFILATI, SUPPORTS  
AND OTHERS ACCESSORIES*

PAG. 60

## LED E ACCESSORI



LED E ACCESSORI

*LED AND ACCESSORIES*

PAG. 65

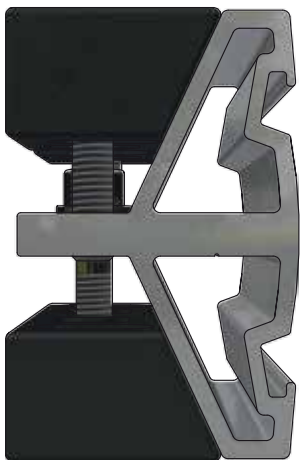

ACCESSORI IN ALLUMINIO  
PER SERRAMENTI, RINGHIERE,  
BALCONI E SCALE

**TGS 001**

I gruppi cunei sono gli elementi che una volta inseriti nel profilo vengono serrati per bloccare meccanicamente il vetro.

Ogni cuneo si compone di un cursore centrale in alluminio, un cuneo superiore ed un cuneo inferiore composti da una speciale lega di fibra di vetro e abs.

*The wedge groups are the elements that, once inserted in the profile, are tightened to mechanically block the glass.*

*Each wedge consists of a central aluminum slider, an upper wedge and a lower wedge made of a special alloy of fiberglass and abs.*

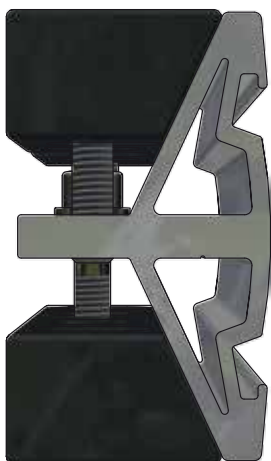
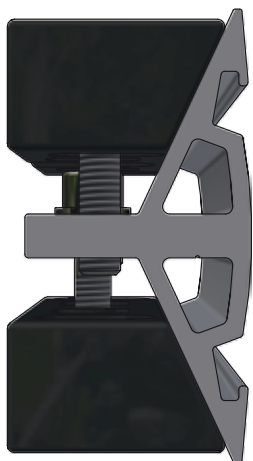

*The slide on the inside is useful to cover a large range of glass inclinations.*

**TGS 002****TGS 003**

**Suggeriamo l'impiego di tre elementi per ogni metro lineare di vetro installato**

*We suggest the use of three elements for each linear meter of glass installed*

## ABBINAMENTO CUNEI-PROFILI

PROFILI	CUNEI		
↓	 TGS 001	 TGS 002	 TGS 003
<b>TGS 50</b>	TGS 50 usa piattelli specifici già inclusi nei profili		
<b>TGS 100</b>	/	Compatibile per vetro 8+1.52+8	Compatibile per vetro 10+1.52+10
<b>TGS 200</b>	/	Compatibile per vetro 8+1.52+8	Compatibile per vetro 10+1.52+10 e 12+1.52+12
<b>TGS 300</b>	Compatibile per vetro 8+1.52+8	Compatibile per vetro 10+1.52+10	
<b>TGS 400</b>	Compatibile per vetro 8+1.52+8	Compatibile per vetro 10+1.52+10	Compatibile per vetro 12+1.52+12
<b>TGS 500</b>	La pensilina utilizza cunei specifici, già forniti con la barra di profilo		
<b>TGS 600</b>	/	Compatibile per vetro 8+1.52+8	Compatibile per vetro 10+1.52+10 e 12+1.52+12

## GUARNIZIONI

### TGS 000

Guarnizione a palloncino colore grigio

NON COMPATIBILE CON TGS 400 E VETRO 8+8  
NON NECESSARIA IN TGS 500 POICHÉ GIÀ  
INCLUDE NEL PROFILO



### TG 309

Guarnizione tradizionale  
colore grigio e nero







## USO DEI CUNEI WEDGES INSTRUCTION



### DISTINTA COMPONENTI COMPONENTS INDEX

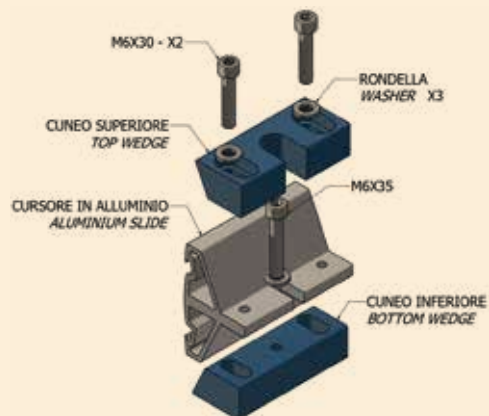

### 1) ASSEMBLARE | ASSEMBLY

#### VITE M6X35 + RONDELLA + CUNEO INFERIORE

Avvitare la vite M6x35 fino a quando il filetto del cuneo non lavora completamente

*Screw in the M6x35 screw until the wedge thread works completely*



Inserire tutto nel cursore in alluminio e bloccare con l'elastico

*Insert everything into the aluminum slider and lock with the elastic*



### 2) INSERIRE | INSERT

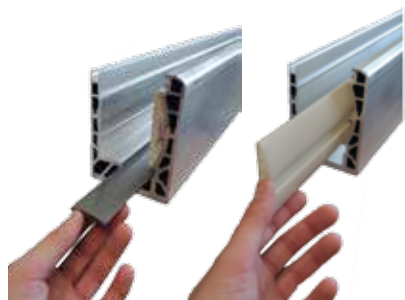

Inserire gli elementi di appoggio del vetro ed eventuale carter esterno con guarnizione

*Insert the glass support elements and the external cover with gasket*



Inserire tutti i cunei precedentemente assemblati. In presenza di spazio laterale è possibile inserirli anche dopo la posa della barra

*Insert all the previously assembled wedges. In the presence of lateral space it is possible to insert them even after installation*



Fissare la barra e inserire il vetro

*Lay and anchor the bar, then insert the glass*

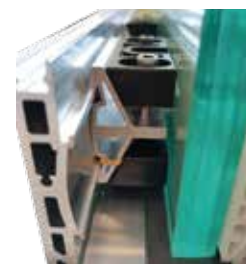

Inserire la parte superiore del cuneo con viti M6X30

*Insert the top wedge with M6x30 screws*

**Nei supporti fronte soletta la procedura è invariata, occorre solamente inserire i cunei prima dell'inserimento del profilo nelle barra filettate**

*In the front floor supports it's mandatory to insert the wedges before inserting the profile into the threaded bars*

### 3) SERRARE | TIGHTEN

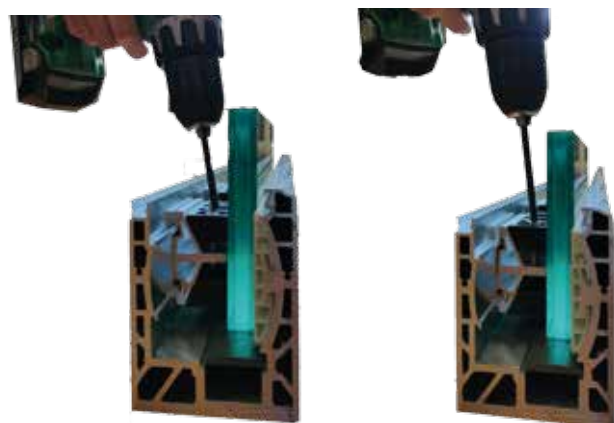

Regolare l'inclinazione del vetro e serrare leggermente tutti i cunei (inferiori e superiori) per mantenerlo in posizione

*Adjust the glass tilt and lightly tighten both top and bottom wedges to hold it in place*

### 4) ULTIMA FASE | LAST STEP

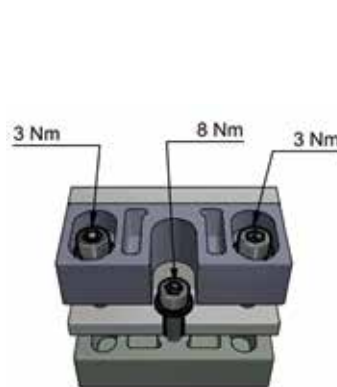

Serrare prima tutti i cunei inferiori a 8 Nm poi tutti i cunei superiori a 3 Nm.

Inserire il carter interno

*First tighten all the bottom wedges at 8 Nm then all the top wedges to 3 Nm.*

*Place the internal cover*



## SERIE TGS 50 SOLUZIONE SOPRA MURETTO | ABOVE WALL

Sistema in barra  
fissaggio sopra muretto  
per vetro 5+1.52+5/6+1.52+6

*Profile bars  
above wall fixing  
for 5+1.52+5/6+1.52+6 glass*

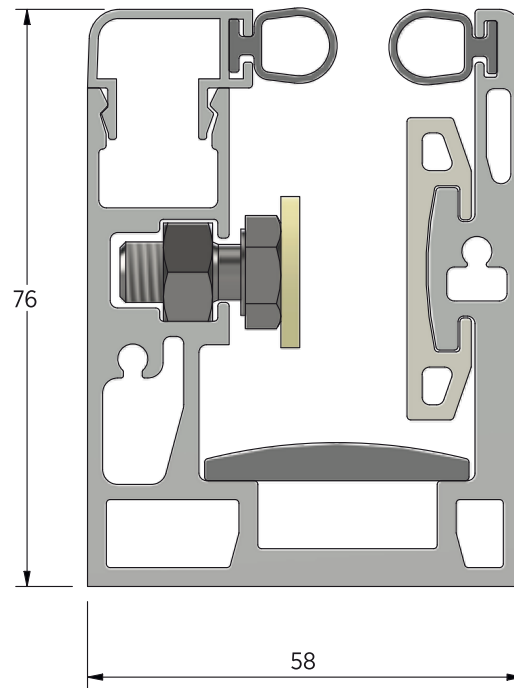

La linea super compatta  
TGS50 è indicata dove è già  
presente una muratura con  
un'altezza tale per cui il  
parapetto in vetro avrà  
un'altezza massima di  
500 mm.

*TGS50 is an extremely  
compact product line,  
designed to be used above  
walls to create glass parapets  
with a maximum height of  
500 mm.*

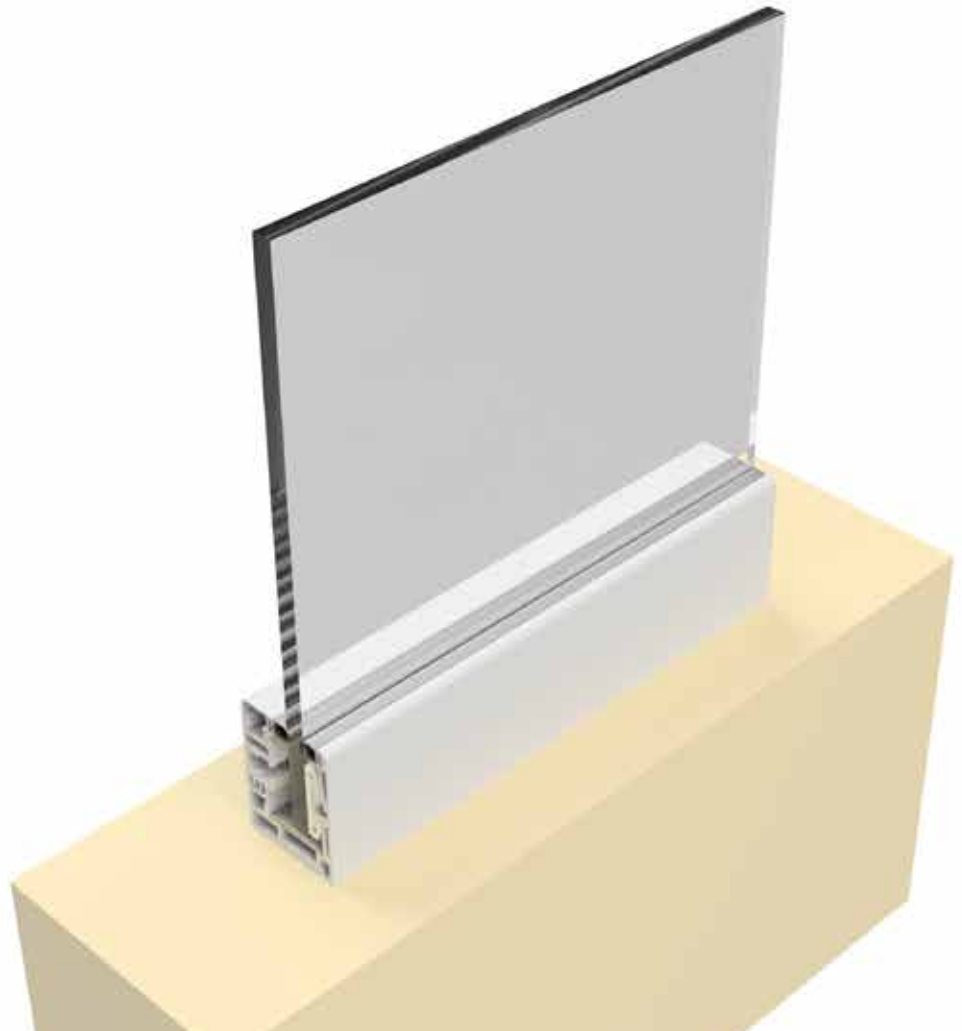

## SOLUZIONE SOPRA MURETTO | ABOVE WALL

### TGS 50

Supporto di fissaggio a pavimento in barra intera da 3000mm per vetri stratificati e temperati da 5+1.52+5/6+1.52+6 mm

*Floor fixing support 3000 mm bar length For 5+1.52+5 and 6+1.52+6 stratified and tempered glass*

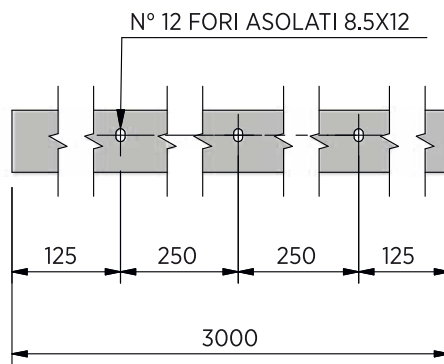

n° 12 fori asolati con interasse 250mm  
n° 12 slotted holes with 250mm center distance

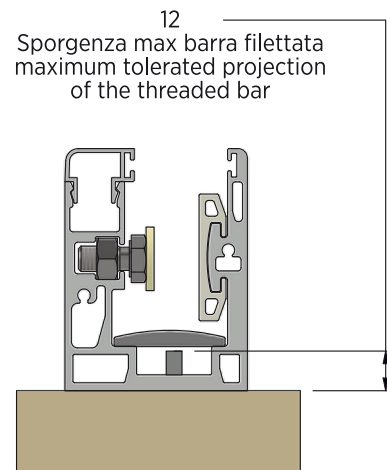

### TGS 51

Supporto di fissaggio a pavimento in barra intera da 6000mm per vetri stratificati e temperati da 5+1.52+5/6+1.52+6 mm

*Floor fixing support 6000 mm bar length For 5+1.52+5 and 6+1.52+6 stratified and tempered glass*

Trasporto a cura del cliente  
*Transport borne by the customer*

PROFILO PROGETTATO PER ANCORANTE M8

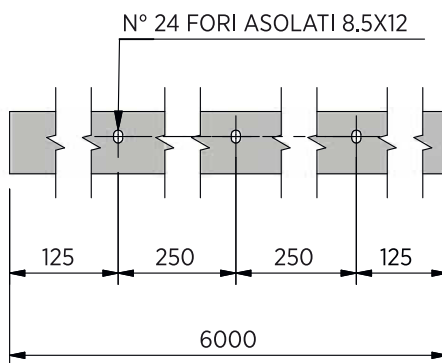

n° 24 fori asolati con interasse 250mm  
n° 24 slotted holes with 250mm center distance

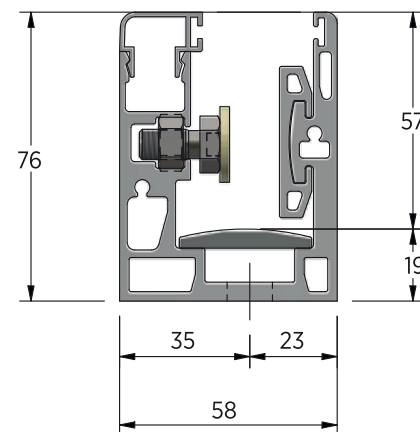

### TGS 52

Tappo laterale  
*Side plug*

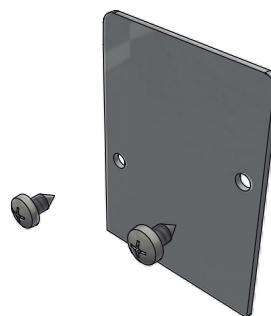

### TGS 53

Chiave ergonomica adatta per stringere comodamente i piattelli di serraggio del vetro

*Ergonomic key Designed to easily tighten the glass locking plates*

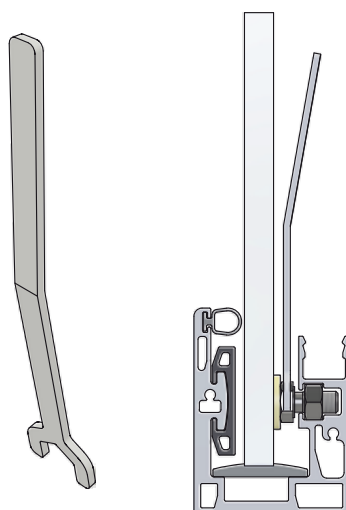

Attenzione: serrare moderatamente i piattelli  
*Attention: moderately tighten the plates*

## SERIE TGS 100

### PAVIMENTO FRONTE SOLETTA | FLOOR BASE SOLUTION

Sistema con fissaggio a pavimento e fronte soletta per vetro 8+1.52+8 e 10+1.52+10 certificato 2 kN/m

*Profile bars for floor fixing and front insole fixing for 8+1.52+8 and 10+1.52+10 glass tested for 2 kN/m*

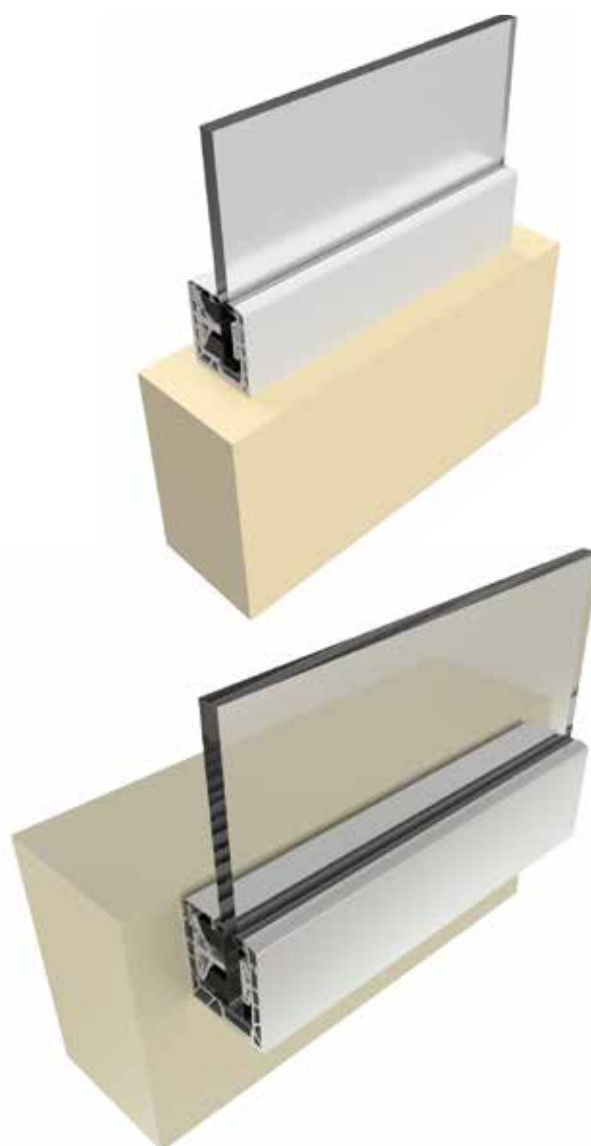
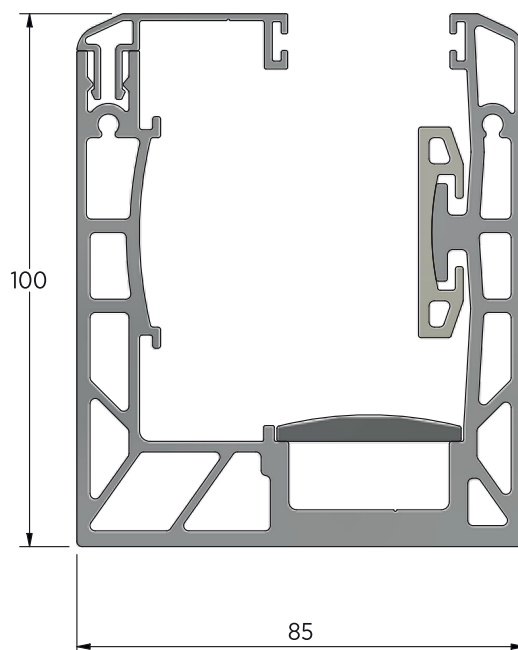

**RAPPORTO DI PROVA**  
*TEST REPORT*



## PAVIMENTO FRONTE SOLETTA | FLOOR BASE SOLUTION

### TGS 100

Supporto di fissaggio a pavimento in barra da 3000mm per vetri stratificati e temperati da 8+1.52+8 e 10+1.52+10

*Floor fixing support  
3000 mm bar length  
For 8+1.52+8 and 10+1.52+10  
stratified and tempered glass*

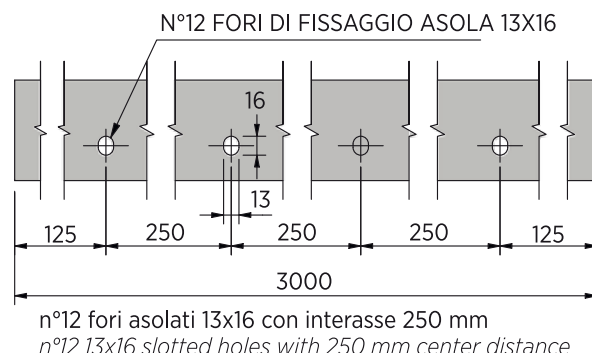
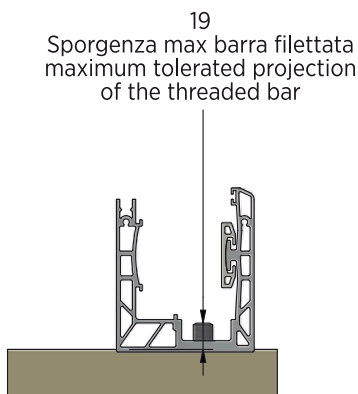

### TGS 101

Supporto di fissaggio a pavimento in barra da 6000mm per vetri stratificati e temperati da 8+1.52+8 e 10+1.52+10

*Floor fixing support  
6000 mm bar length  
For 8+1.52+8 and 10+1.52+10  
stratified and tempered glass*

Trasporto a cura del cliente  
*Transport borne by the customer*

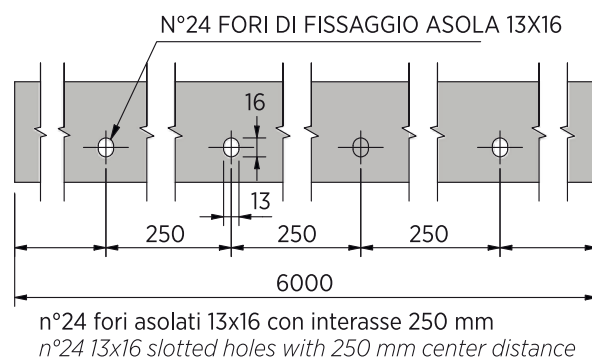
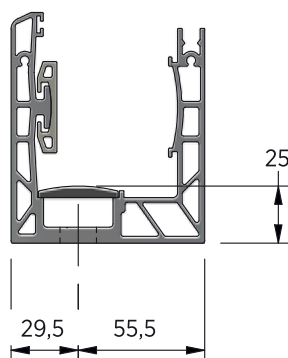

### TGS 102

Supporto per fronte muretti in barra da 3000 mm Per vetri stratificati e temperati da 8+1.52+8 e 10+1.52+10

*Front wall support in full bar,  
3000 mm length, only for low  
height parapets.  
For 8+1.52+8 and 10+1.52+10  
stratified and tempered glass*

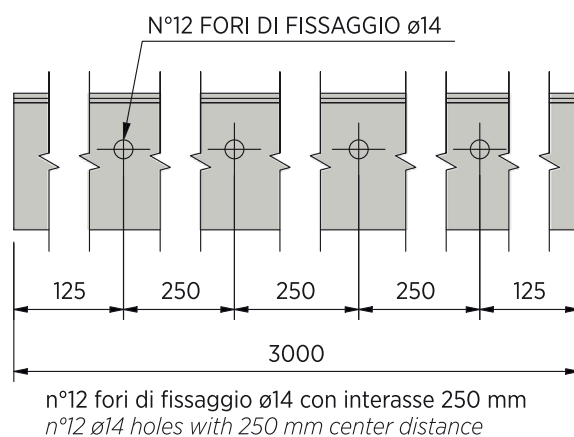
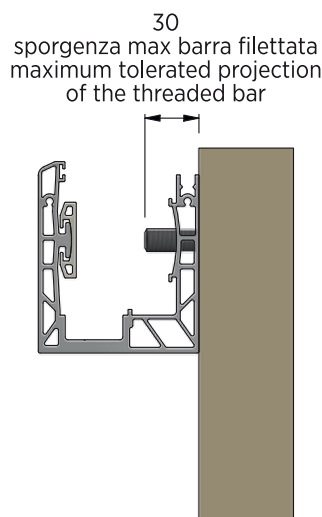

### TGS 103

Supporto per fronte muretti in barra da 6000 mm Per vetri stratificati e temperati da 8+1.52+8 e 10+1.52+10

*Front wall support in full bar,  
6000 mm length, only for low  
height parapets.  
For 8+1.52+8 and 10+1.52+10  
stratified and tempered glass*

Trasporto a cura del cliente  
*Transport borne by the customer*

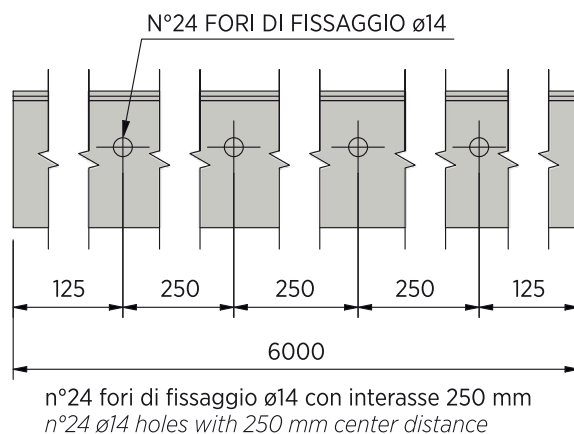
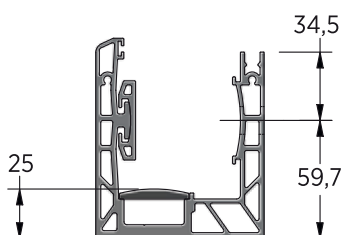

PAVIMENTO FRONTE SOLETTA | FLOOR BASE SOLUTION

**TGS 104**

Tappo laterale per  
TGS100-101-102-103

Side plug for  
TGS100-101-102-103

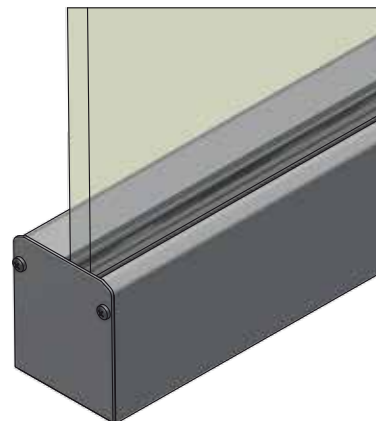
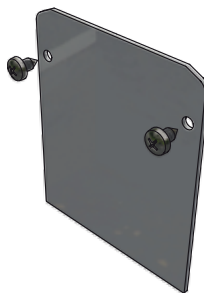

**TGS 105**

Profilo scarico acque  
per supporti a pavimento  
(L.3000 mm)  
TGS 100-101

Water exhaust profile for floor  
fixed supports (L.3000 mm)  
TGS 100-101

Le barre sono già forate e  
predisposte per il fissaggio

Profile bars are provided  
with fixing holes

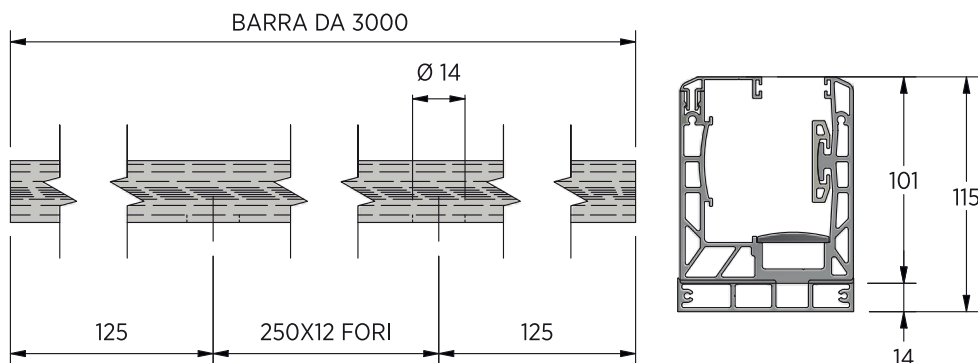

**TGS 106**

Profilo scarico acque  
per supporti a pavimento  
(L.6000 mm)  
TGS 100-101

Water exhaust profile for floor  
fixed supports (L.6000 mm)  
TGS 100-101

Le barre sono già forate e  
predisposte per il fissaggio

Profile bars are provided  
with fixing holes

Trasporto a cura del cliente

Transport borne by the customer

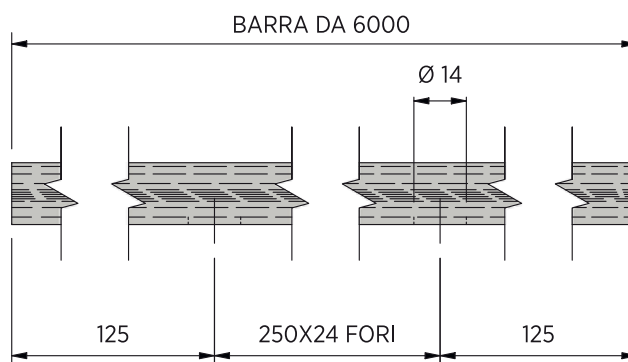

**TGS 107**

Tappo per profili  
scarico acque

Water exhaust profile plug

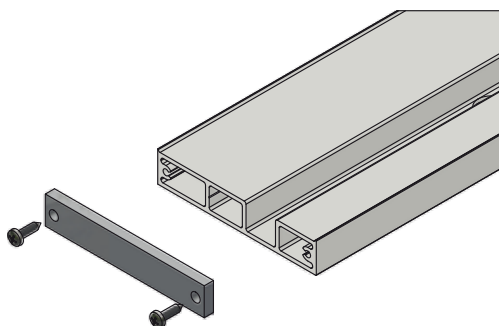

Montare il tappo prima della posa del profilo scarico acque  
Plug must be fitted before laying the water drainage profile

## SERIE TGS 200

### PAVIMENTO FRONTE SOLETTA | FLOOR BASE SOLUTION

Sistema con fissaggio a pavimento e fronte soletta per vetro 8+1.52+8 e 10+1.52+10 certificato 2 kN/m

*Profile bars for floor fixing and front insole fixing for 8+1.52+8 and 10+1.52+10 glass tested for 2 kN/m*

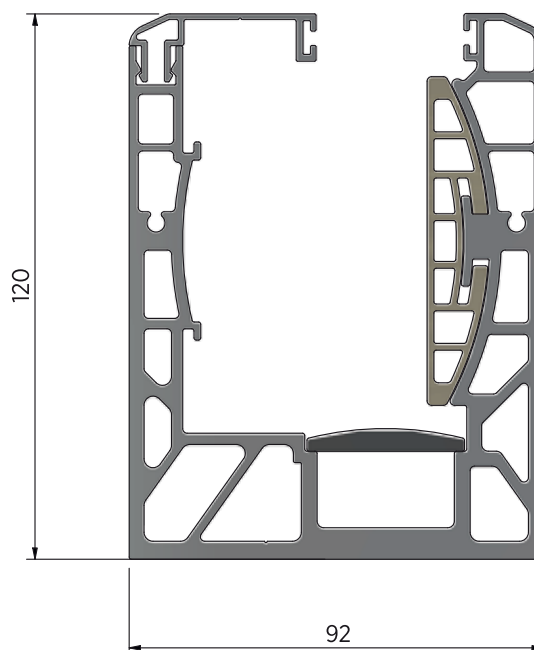

RAPPORTO DI PROVA  
TEST REPORT



## PAVIMENTO FRONTE SOLETTA | FLOOR BASE SOLUTION

### TGS 200

Supporto di fissaggio a pavimento in barra da 3000mm per vetri stratificati e temperati da 8+1.52+8 e 10+1.52+10.

*Floor fixing support  
3000 mm bar length.  
For 8+1.52+8 and 10+1.52+10  
stratified and tempered glass.*

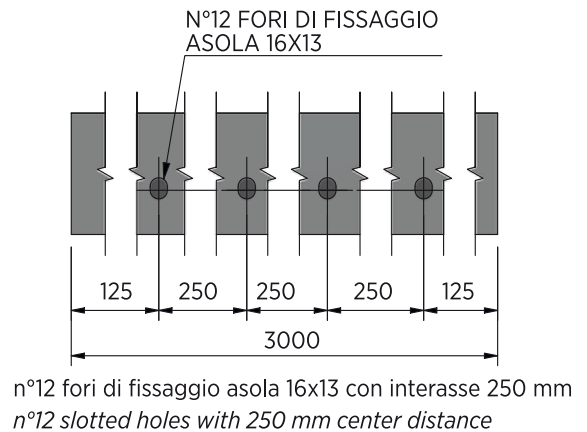
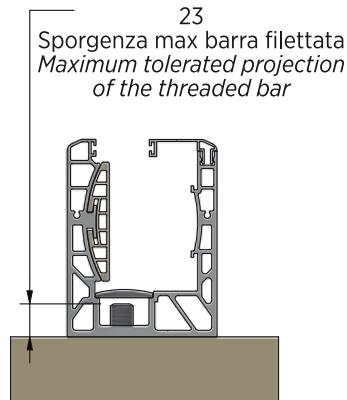

### TGS 201

Supporto di fissaggio a pavimento in barra da 6000mm per vetri stratificati e temperati da 8+1.52+8 e 10+1.52+10  
Trasporto a cura del cliente

*Floor fixing support  
6000 mm bar length  
For 8+1.52+8 and 10+1.52+10  
stratified and tempered glass  
Transport borne by the customer*

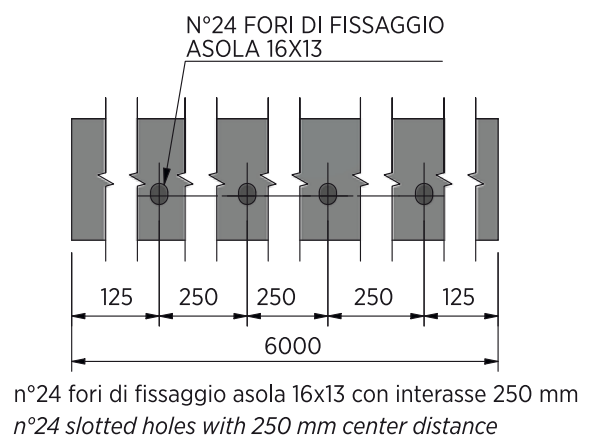
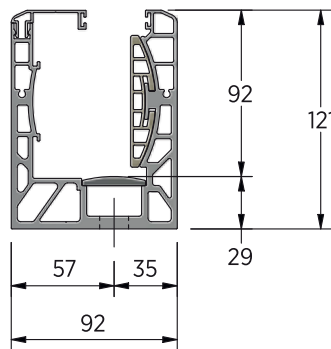

### TGS 202

Supporto per fronte muretti in barra da 3000 mm  
Per vetri stratificati e temperati da 8+1.52+8 e 10+1.52+10

*Front wall support in full bar,  
3000 mm length.  
For 8+1.52+8 and 10+1.52+10  
stratified and tempered glass*

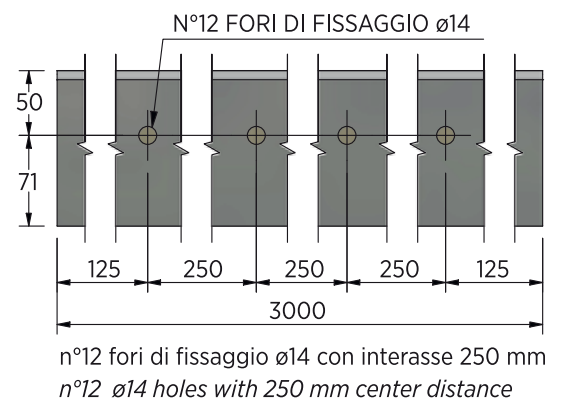
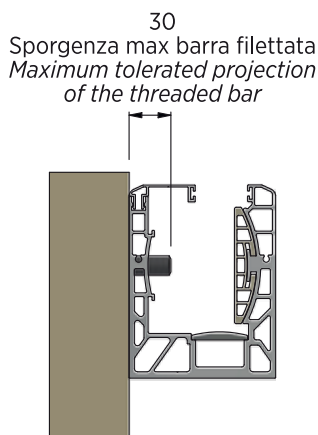

### TGS 203

Supporto per fronte muretti in barra da 6000 mm  
Per vetri stratificati e temperati da 8+1.52+8 e 10+1.52+10

*Front wall support in full bar,  
6000 mm length.  
For 8+1.52+8 and 10+1.52+10  
stratified and tempered glass*

Trasporto a cura del cliente  
*Transport borne by the customer*

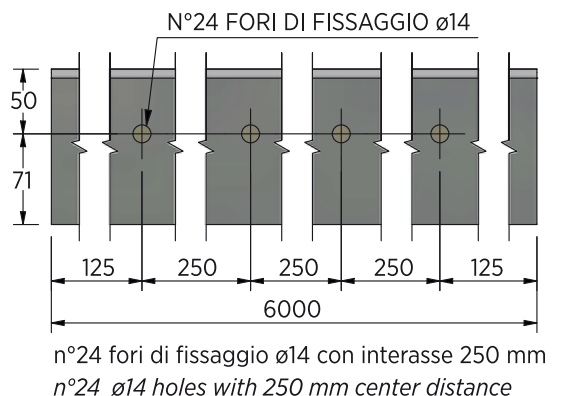
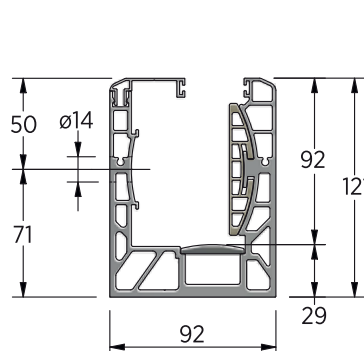



PAVIMENTO FRONTE SOLETTA | FLOOR BASE SOLUTION

**TGS 204**

Tappo per supporti a pavimento

*Floor supports side plug*



**TGS 205**

Profilo scarico acque per supporti a pavimento. Lunghezza profilo 3000 mm Per TGS200-TGS600

*Water exhaust profile for floor fixed supports. Profile length 3000 mm For TGS200-TGS600*

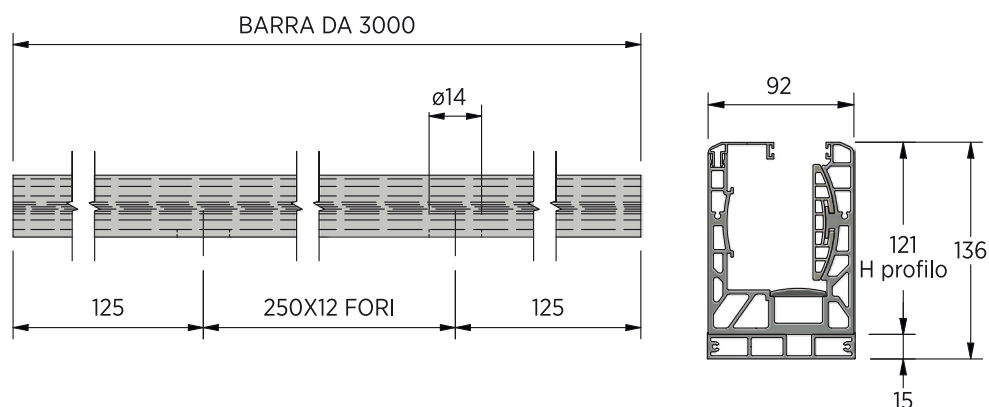

**TGS 206**

Profilo scarico acque per supporti a pavimento. Lunghezza profilo 6000 mm Per TGS200-TGS600 Trasporto a cura del cliente

*Water exhaust profile for floor fixed supports. Profile length 6000 mm For TGS200-TGS600 Transport borne by the costumer*

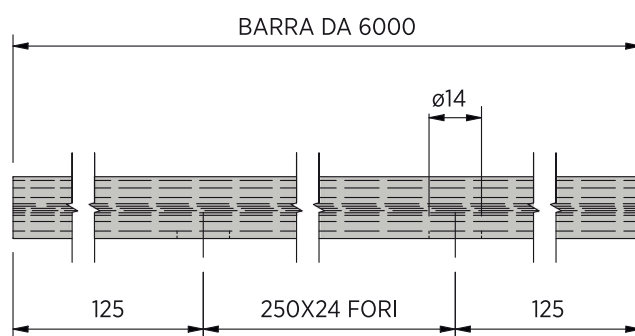

**TGS 207**

Tappo per profili scarico acque

*Water exhaust profile plug*

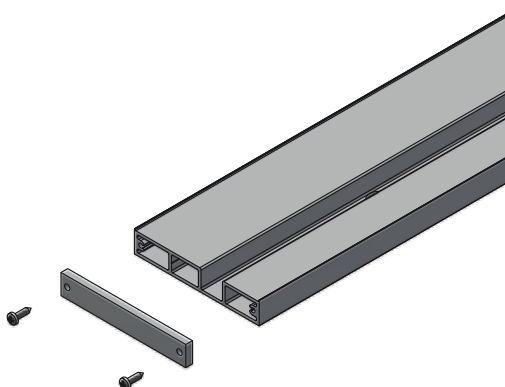

**SERIE TGS 300**

**FISSAGGIO A SCOMPARSA | CONCEALED FIXING**

Sistema con fissaggio a pavimento incassato per vetro 8+1.52+8 e 10+1.52+10 certificato 2 kN/m

*Profile bars for embedded floor fixing for 8+1.52+8 and 10+1.52+10 glass tested for 2 kN/m*

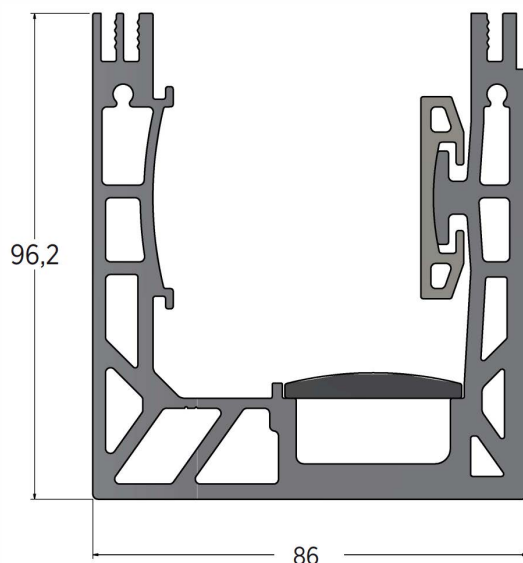

Nei profili ad incasso occorre prevedere un sistema scarico acque esterno, integrato nella muratura.

*Embedded profiles don't integrate a rainwater drainage system, which must be built into the masonry*

**RAPPORTO DI PROVA**  
*TEST REPORT*

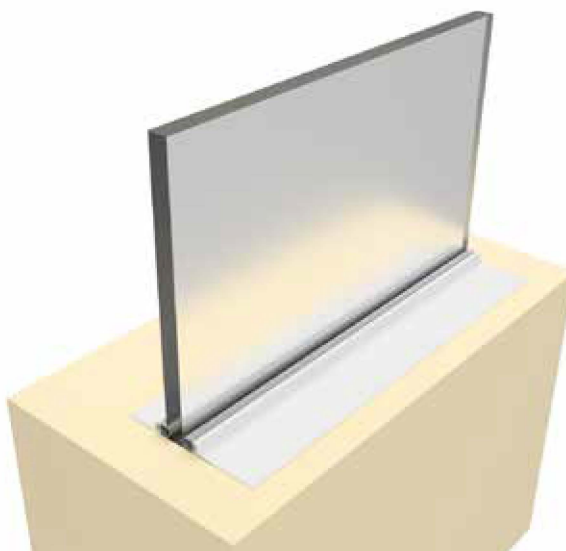

“Nuova passerella pedonale a Porta a Mare che unisce gli Scali Nuovi Lena al retro di Palazzo Orlando. Foto di Lorenzo Amore Bianco per Quilivorno.it”

*“New footbridge at Porta a Mare which unites the Scali Nuovi Lena at the rear of Palazzo Orlando. Photo by Lorenzo Amore Bianco for Quilivorno.it”*



## FISSAGGIO A SCOMPARSITA | CONCEALED FIXING

### TGS 300

Supporto di fissaggio ad incasso in barra da 3000mm per vetri stratificati e temperati da 8+1.52+8 e 10+1.52+10

*Built-in support 3000 mm bar length. For 8+1.52+8 and 10+1.52+10 stratified and tempered glass*

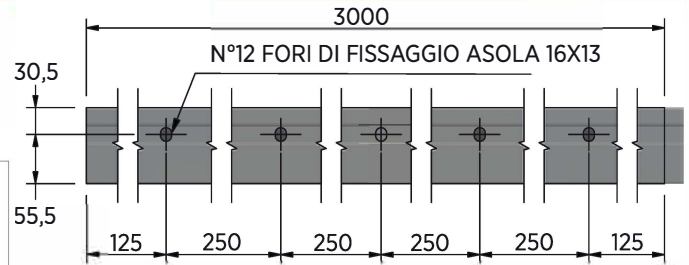
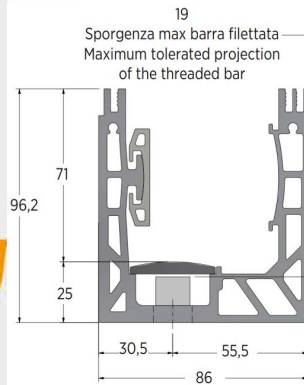

\*N° 12 fori asolati 13x16 con interasse mm 250  
N° 12 slotted holes 13x16 with 250 mm center distance

### TGS 301

Supporto di fissaggio ad incasso in barra da 6000mm per vetri stratificati e temperati da 8+1.52+8 e 10+1.52+10

*Built-in support 6000 mm bar length. For 8+1.52+8 and 10+1.52+10 stratified and tempered glass. Transport borne by the customer*

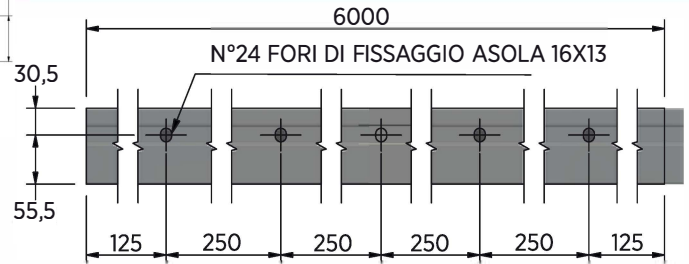

\*N° 24 fori asolati 13x16 con interasse mm 250  
N° 24 slotted holes 13x16 with 250 mm center distance

### TGS 302

Copertella interna, barra da 3000 mm

*Internal cover, 3000 mm bar length*

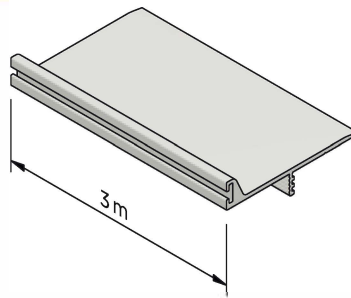

Utilizzare le apposite scanalature di aggancio in base allo spessore e all'inclinazione del vetro, in modo che la guarnizione aderisca in maniera uniforme al vetro. Si consiglia di incollare la copertella con alcune gocce di silicone nella scanalatura.

*Use the specific coupling grooves according to the glass thickness and inclination, in order for the seal to uniformly adhere to the glass. It is recommended to glue the cover putting some drops of silicone into the grooves*

### TGS 303

Copertella interna, barra da 6000 mm  
Trasporto a cura del cliente

*Internal cover, 6000 mm bar length  
Transport borne by the customer*

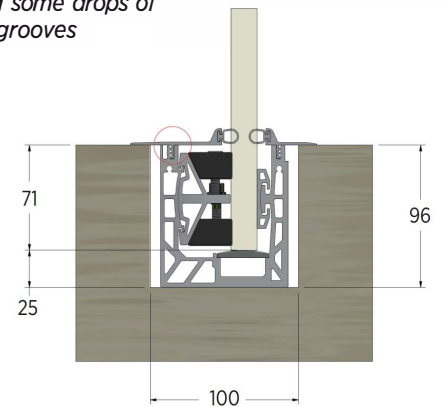
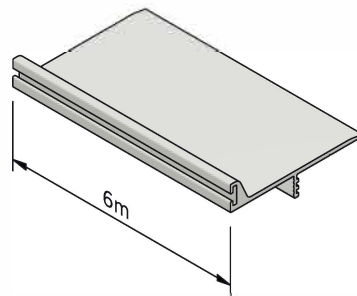

### TGS 304

Copertella esterna, barra da 3000 mm

*External cover, 3000 mm bar length*

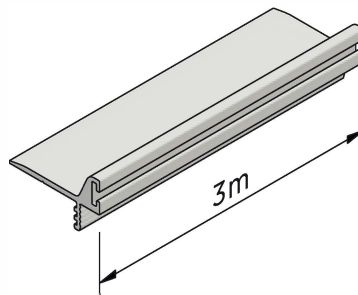

Utilizzare le apposite scanalature di aggancio in base allo spessore e all'inclinazione del vetro. Si consiglia di incollare la copertella con alcune gocce di silicone nella scanalatura.

*Use the specific coupling grooves according to the glass thickness and inclination, in order for the seal to uniformly adhere to the glass. It is recommended to glue the cover putting some drops of silicone into the grooves.*

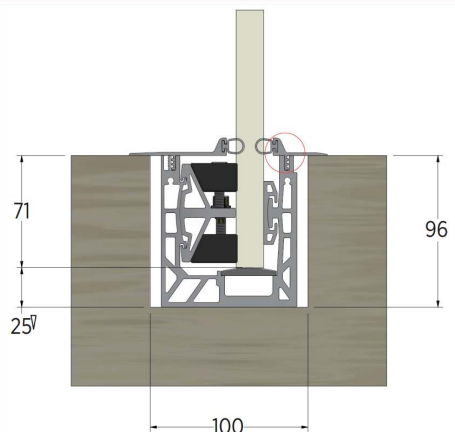

FISSAGGIO A SCOMPARSA | CONCEALED FIXING

**TGS 305**

Copertella esterna,  
barra da 6000 mm.  
Trasporto a cura del cliente.

*External cover, 6000 mm  
bar length.  
Transport borne by the customer*

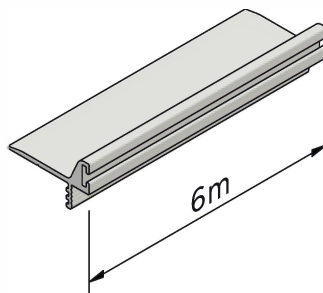

Utilizzare le apposite scanalature di aggancio in base allo spessore e all'inclinazione del vetro. Si consiglia di incollare la copertella con alcune gocce di silicone nella scanalatura.

*Use the specific coupling grooves according to the glass thickness and inclination, in order for the seal to uniformly adhere to the glass. It is recommended to glue the cover putting some drops of silicone into the grooves.*

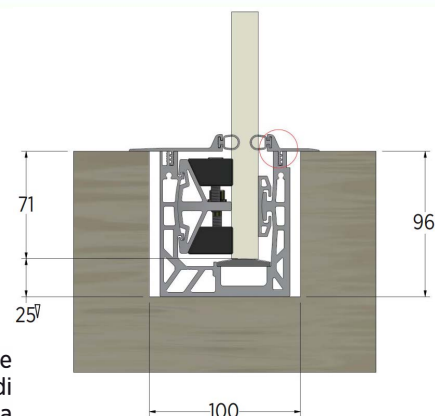

**GU 102**

Guarnizione chiusura laterale  
*Side closure seal*

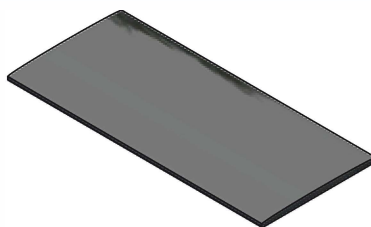

## SERIE TGS 400

### PAVIMENTO E FRONTE SOLETTA | FLOOR AND FRONT SLAB

Sistema con fissaggio a pavimento e fronte soletta per vetro  
8+1.52+8 / 10+1.52+10  
12+1.52+12  
certificato 2 kN/m

*Profile bars for floor fixing and front insole fixing for  
8+1.52+8 / 10+1.52+10  
12+1.52+10  
glass tested for 2 kN/m*

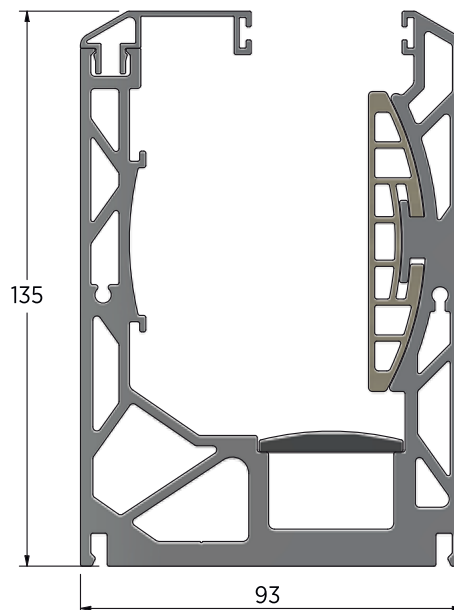

RAPPORTO DI PROVA  
TEST REPORT



**TGS 400**

Supporto di fissaggio a pavimento in barra da 3000mm per vetri stratificati e temperati da 8+1.52+8 / 10+1.52+10 / 12+1.52+12

*Floor fixing support 3000 mm bar length. For 8+1.52+8 / 10+1.52+10 / 12+1.52+10 stratified and tempered glass.*

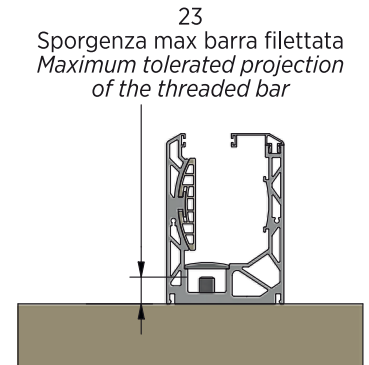
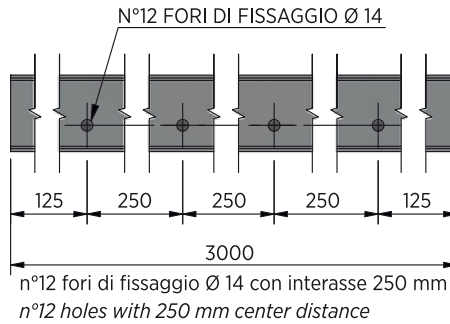

**TGS 401**

Supporto di fissaggio a pavimento in barra da 6000mm per vetri stratificati e temperati da 8+1.52+8 / 10+1.52+10 / 12+1.52+12 Trasporto a cura del cliente

*Floor fixing support 6000 mm bar length For 8+1.52+8 / 10+1.52+10 / 12+1.52+10 stratified and tempered glass Transport borne by the customer*

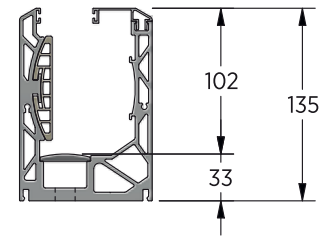
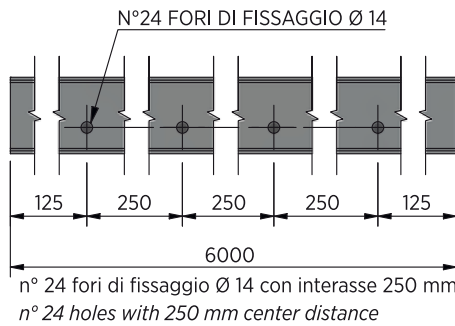

**TGS 402**

Supporto di fissaggio fronte soletta in barra da 3000 mm Per vetri stratificati e temperati da 8+1.52+8 / 10+1.52+10 / 12+1.52+12

*Front wall fixing support, 3000 mm bar length. For 8+1.52+8 / 10+1.52+10 / 12+1.52+10 stratified and tempered glass*

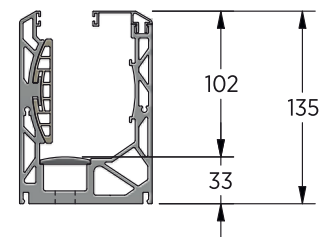
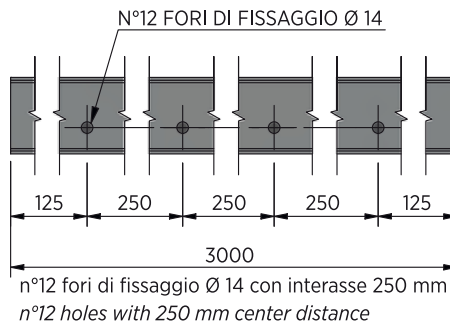

**TGS 403**

Supporto di fissaggio fronte soletta in barra da 6000 mm Per vetri stratificati e temperati da 8+1.52+8 / 10+1.52+10 / 12+1.52+12 Trasporto a cura del cliente

*Front wall fixing support, 6000 mm bar length. For 8+1.52+8 / 10+1.52+10 / 12+1.52+10 stratified and tempered glass Transport borne by the customer*

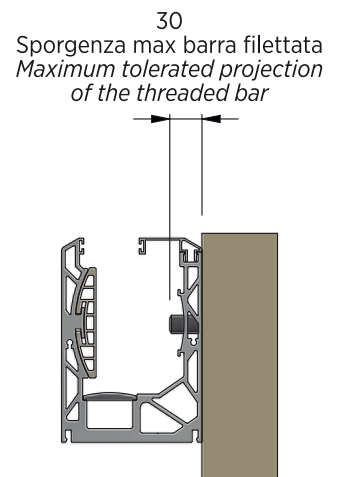
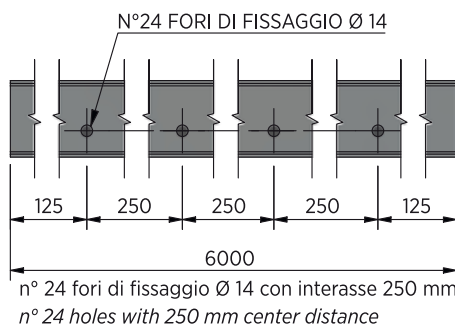

### TGS 404

Tappo per supporti a pavimento  
a pavimento

*Floor supports  
side plug*

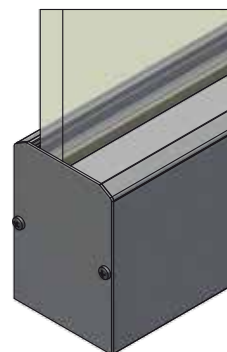
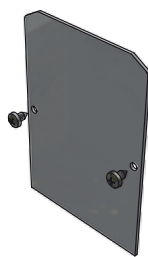

### TG 813

Profilo scarico acque  
per supporti a pavimento.  
Lunghezza profilo 3000 mm  
Per TGS400-TGS401  
Le barre sono già forate e  
predisposte per il fissaggio

*Water exhaust profile for floor  
fixed supports.*

*Profile length 3000 mm  
For TGS400-401*

*Profile bars are provided  
with fixing holes*

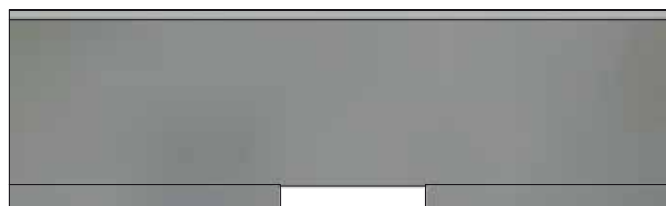
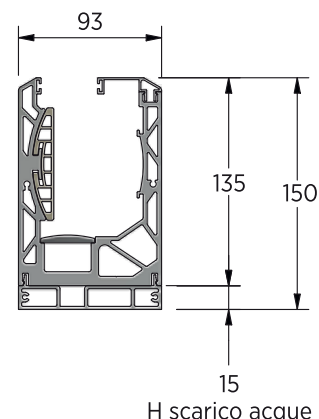
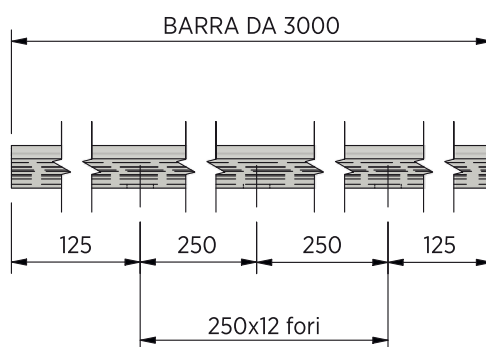

### TG 814

Profilo scarico acque  
per supporti a pavimento.  
Lunghezza profilo 6000 mm  
Per TGS400-TGS401  
Le barre sono già forate e  
predisposte per il fissaggio  
Trasporto a cura del cliente

*Water exhaust profile for floor  
fixed supports.*

*Profile length 6000 mm  
For TGS400-401*

*Profile bars are provided  
with fixing holes  
transport borne by the customer*

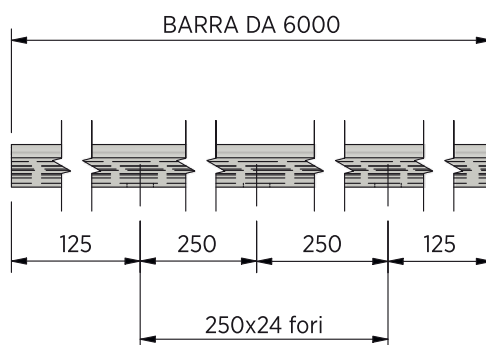

### TG 815

Tappo per profili scarico acque

*Water exhaust profile plug*

Montare il tappo prima della posa  
del profilo scarico acque

*Fit the plug before laying the  
water drainage profile*

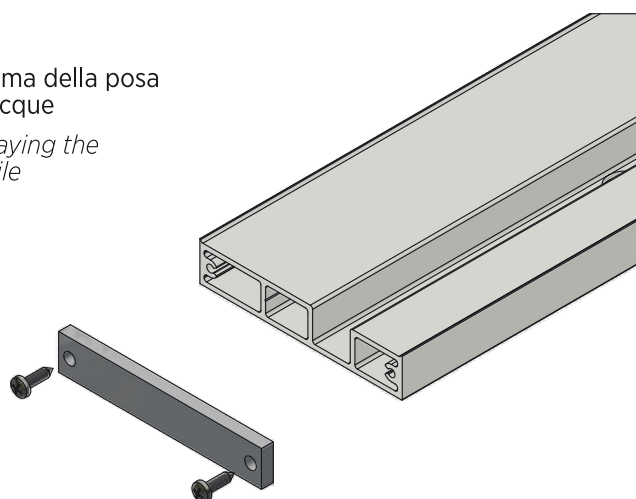

**TG 816**

Copertella per supporti fronte soletta (L.3000 mm) per supporti TGS 402-TGS 403

*Fronti wall supports cover (L.3000 mm) for TGS 402-TGS 403*

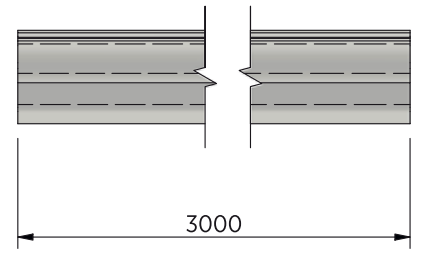
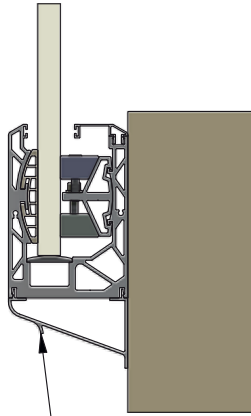

**TG 817**

Copertella per supporti fronte soletta (L.6000 mm) per supporti TGS 402-TGS 403

*Front wall supports cover (L.6000 mm) for TGS 402-TGS 403*

Trasporto a cura del cliente  
*Transport by the customer*

Dotato di rompigoccia  
*With drip profile*

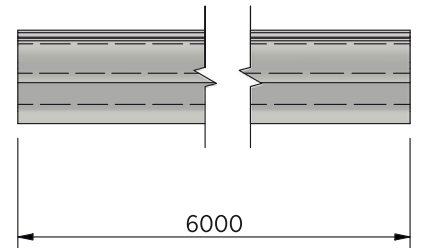

**TGS 405**

Tappo per supporti fronte soletta

*Front side support plug*

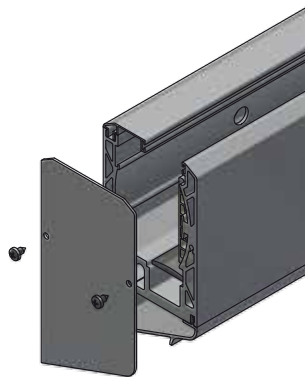

**TGS 406**

Tappo fronte soletta, uso scale

*Side plug for stairs use only*

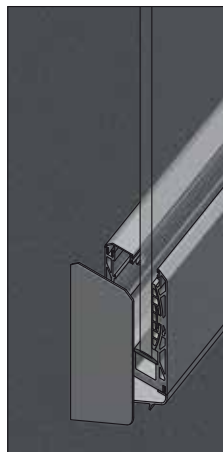



**SERIE TGS 500**  
**PENSILINA | CANOPY**

Profilo pensilina solo per vetro 10+1.52+10 temperato testata al carico neve e vento zona alpina (165 kg/m<sup>2</sup>) con perni di sicurezza per ritenuta del vetro predisposta per illuminazione led

*Shelter profile only for 10+1.52+10 tempered glass tested to snow and wind load in the alpine area (165 kg/m<sup>2</sup>) provided with safety pins for glass retention prepared for led lighting*

**RAPPORTO DI PROVA**  
**TEST REPORT**

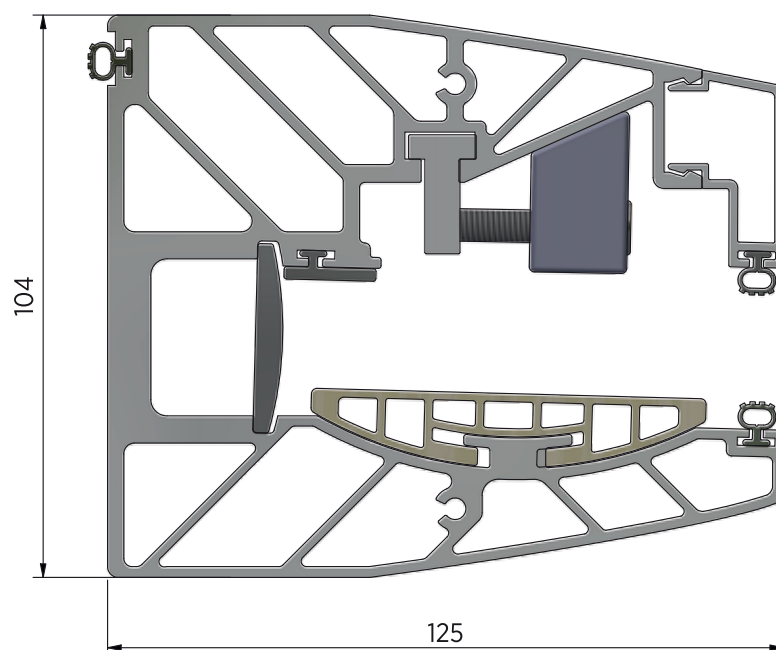

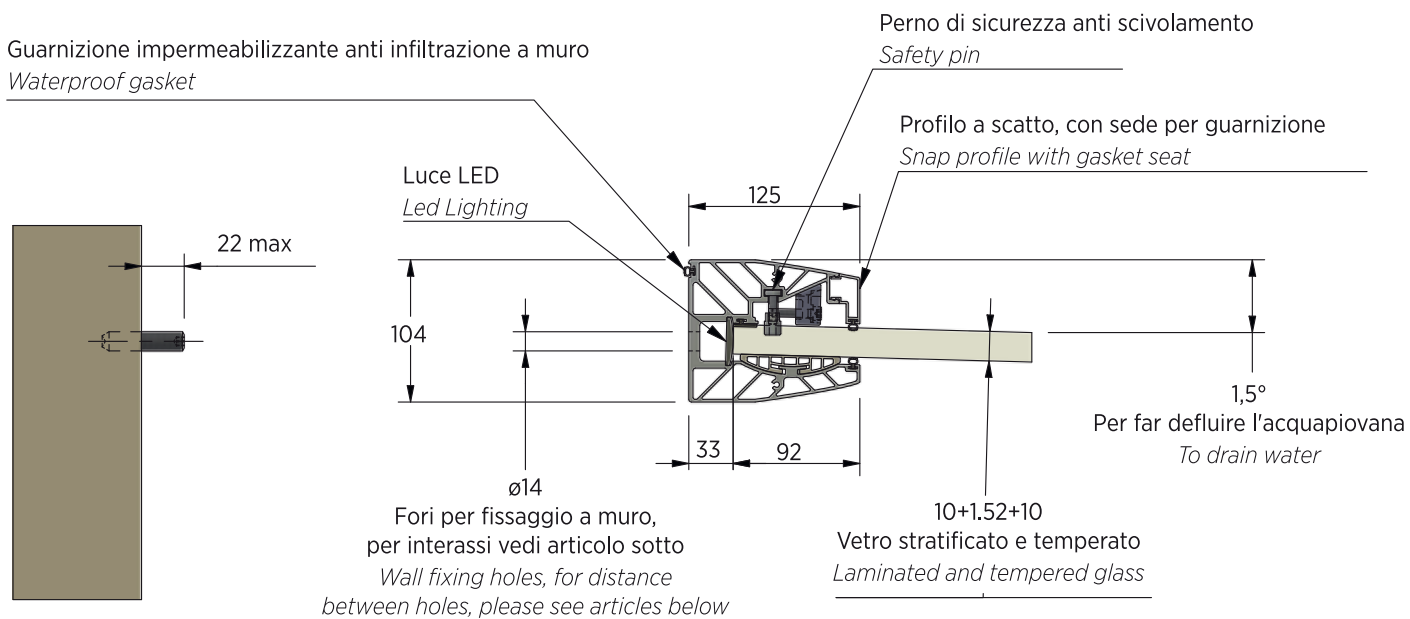

**Nelle pagine seguenti sono riportate le istruzioni di montaggio dettagliate**  
*For detailed assembly instructions, please see the following pages*

**TGS 500**

Pensilina in barra da 3000 mm per vetro 10+1.52+10  
*Canopy, 3000 mm profile bar For 10+1.52+10 glass*

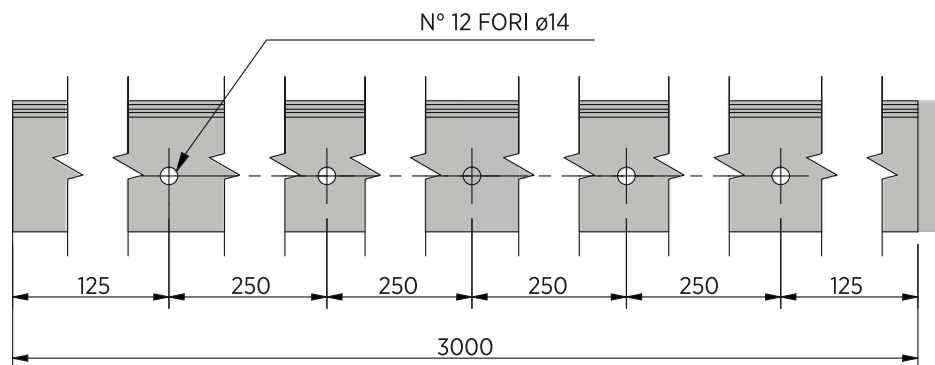

**TGS 501**

Pensilina in barra da 6000 mm per vetro 10+1.52+10  
Trasporto a cura del cliente  
*Canopy, 6000 mm profile bar For 10+1.52+10 glass Transport borne by the customer*

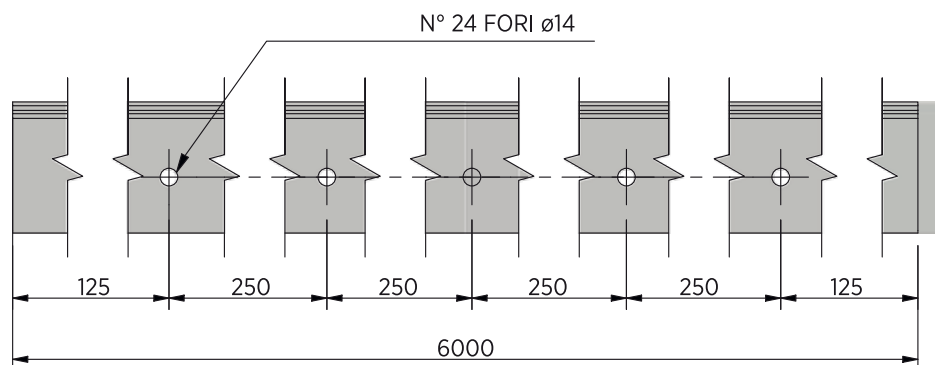

**TGS 502**

Tappo per pensilina completo di guarnizione  
*Canopy profile plug, provided with waterproofing gasket*

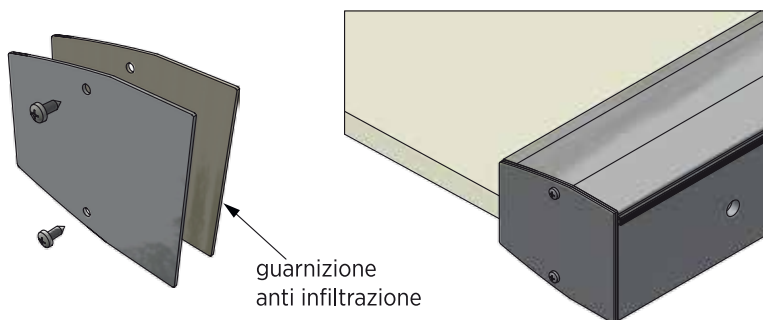

**1. FISSARE LE BARRE FILETTATE**

FIX THE THREADED BARS

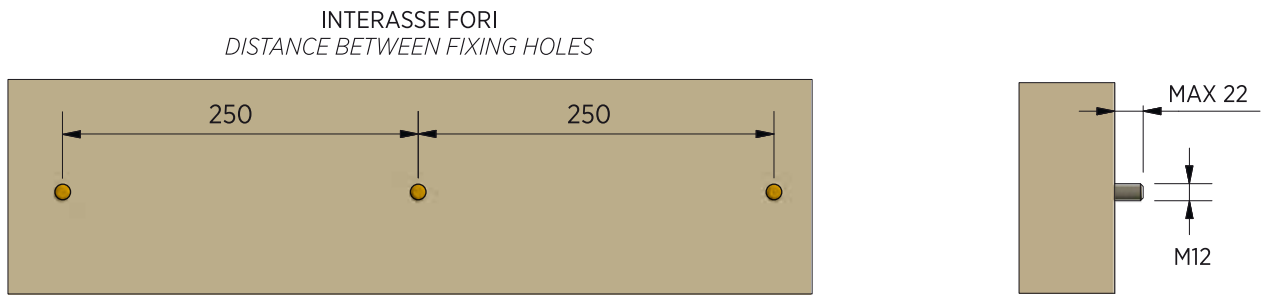

I supporti sono predisposti con fori asolati 13x16 e interasse 250 mm, le asole garantiscono del margine di regolazione. Lasciare sporgere la barra filettata di massimo 22 mm.

Supports are provided with 13x16 slotted holes and 250 mm center distance, slotted holes allow an adjustment margin. Let the threaded bar of maximum 22 mm protrude

**2. INSERIRE LE PIASTRINE TRASPARENTI PORTA LED IN POLICARBONATO, GLI APPOGGI PER VETRO IN NYLON E I PIATTELLI FERMAVETRO. INFILARE LA GUARNIZIONE POSTERIORE NELL'APPOSITA CAVA PRESENTE NEL PROFILO, EVITERÀ INFILTRAZIONI TRA MURO E SUPPORTO.**

INSERT THE TRANSPARENT POLYCARBONATE LED HOLDER PLATES, NYLON GLASS SUPPORTS AND NYLON HEXAGONAL PLATES. INSERT ALSO THE REAR WATERPROOFING GASKET IN HIS SPECIFIC CAVE IN THE PROFILE.

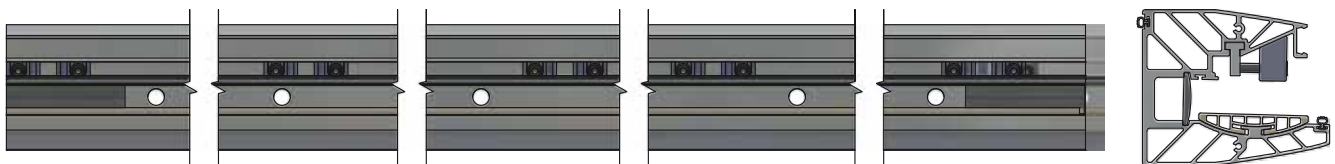

**3. FISSARE LA PENSILINA CON RONDELLA E DADO AUTOBLOCCANTE, OPPURE CON RONDELLA E VITE M12. UNA VOLTA FISSATA, INSERIRE LE GUARNIZIONI INTERNE COME RIPORTATO NELL'IMMAGINE.**

FIX THE CANOPY PROFILE WITH WASHER AND SELF-LOCKING NUT, OR WITH WASHER AND M12 SCREW. ONCE FIXED, INSERT THE INTERNAL GASKETS AS SHOWN IN THE IMAGE.

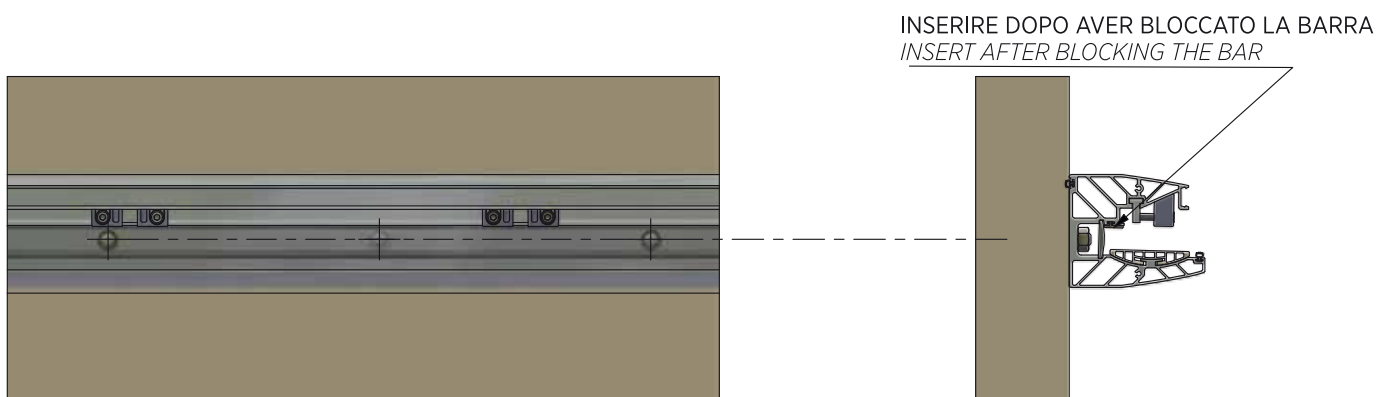

**4. LAVORAZIONI SUL VETRO STRATIFICATO TEMPERATO DI SPESSORE 10+1.52+10**  
 HOLES INDICATION FOR 10+1,52+10 STRATIFIED AND TEMPERED GLASS

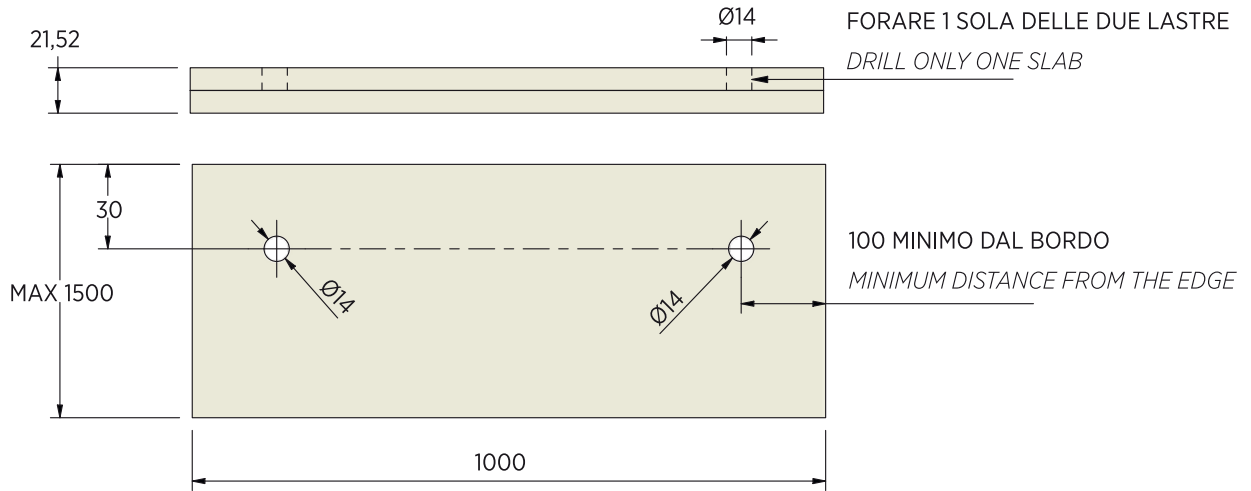

**5. INSERIRE IL VETRO E SERRARE I PIATTELLI, INFINE INSERIRE IL CARTER DI CHIUSURA CON RELATIVA GUARNIZIONE.**  
 INSERT THE GLASS AND TIGHTEN THE PLATES, THEN INSERT CLOSING COVER WITH RELATIVE GASKET.



**6. CHIUDERE LATERALMENTE CON GUARNIZIONE IMPERMEABILIZZANTE E TAPPI (ARTICOLO TG 702).**  
 CLOSE LATERALLY WITH WATERPROOFING GASKET AND CAPS (ARTICLE TG 702).

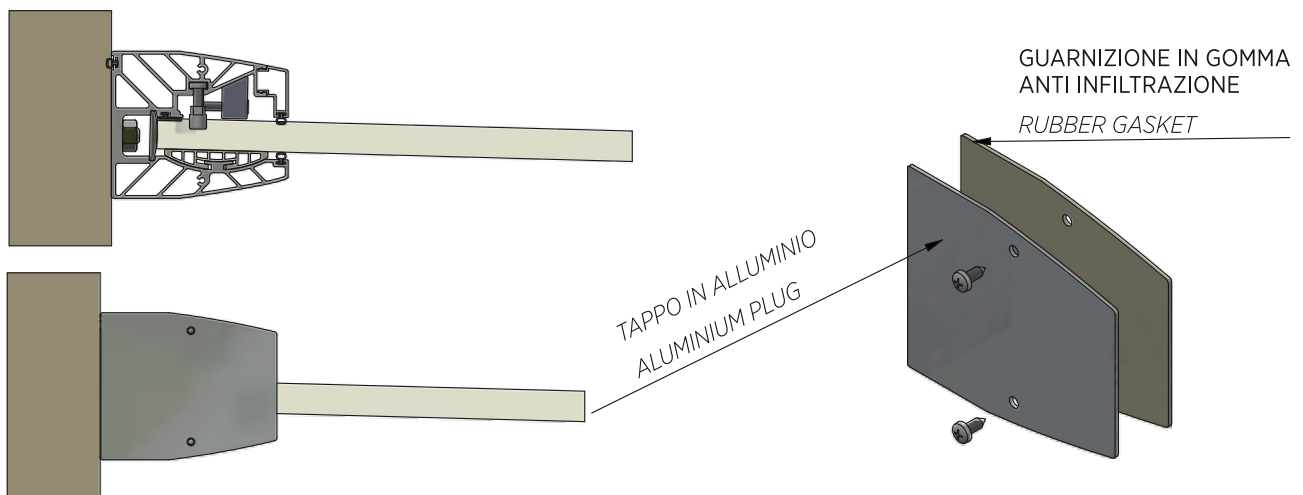

## SERIE TGS 600

PER PARAPETTI EDILIZIA PUBBLICA | FOR PUBLIC BUILDING PARAPETS

Sistema con fissaggio a pavimento e fronte soletta per vetro 8+1.52+8 / 10+1.52+10 / 12+1.52+12 certificato 2 e 3 kN/m

*Profile bars for floor fixing and front insole fixing for 8+1.52+8 / 10+1.52+10 / 12+1.52+10 glass tested for 2 and 3 kN/m*

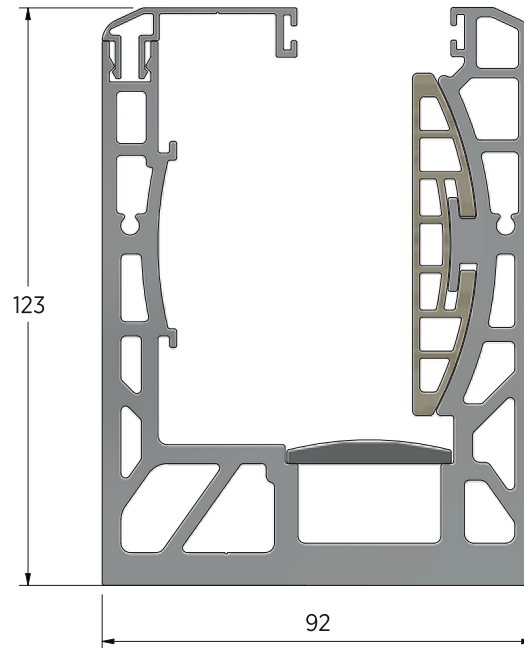

RAPPORTO DI PROVA  
TEST REPORT



### TGS 600

Supporto di fissaggio a pavimento in barra da 3000mm per vetri stratificati e temperati da 8+1.52+8 / 10+1.52+10 / 12+1.52+12

*Floor fixing support 3000 mm bar length. For 8+1.52+8 / 10+1.52+10 / 12+1.52+10 stratified and tempered glass.*

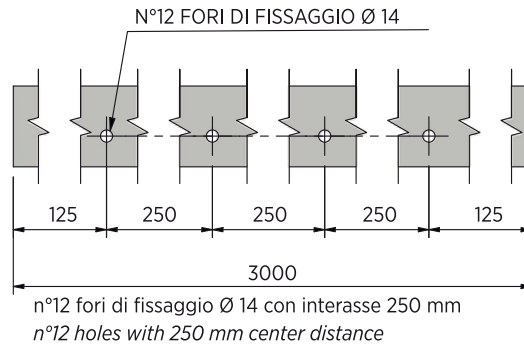

23  
Sporgenza max barra filettata  
Maximum tolerated projection  
of the threaded bar

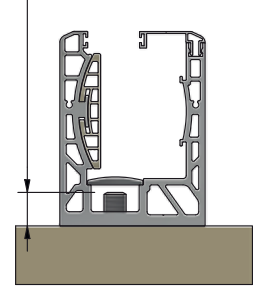

### TGS 601

Supporto di fissaggio a pavimento in barra da 6000mm per vetri stratificati e temperati da 8+1.52+8 / 10+1.52+10 / 12+1.52+12  
Trasporto a cura del cliente

*Floor fixing support 6000 mm bar length. For 8+1.52+8 / 10+1.52+10 / 12+1.52+10 stratified and tempered glass. Transport borne by the customer*

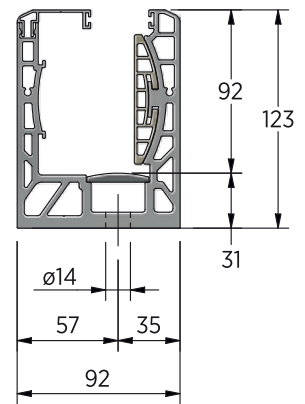
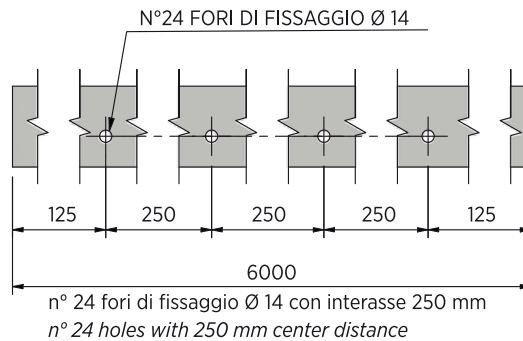

### TGS 602

Supporto di fissaggio fronte soletta in barra da 3000 mm  
Per vetri stratificati e temperati da 8+1.52+8 / 10+1.52+10 / 12+1.52+12

*Front wall fixing support, 3000 mm bar length. For 8+1.52+8 / 10+1.52+10 / 12+1.52+10 stratified and tempered glass*

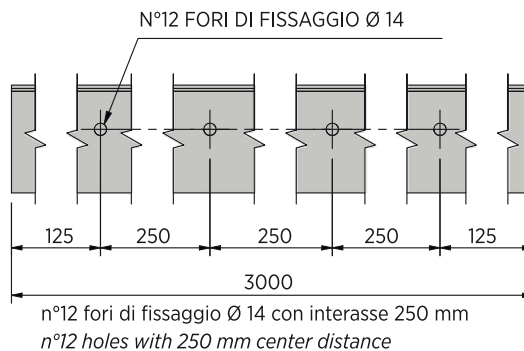

30  
Sporgenza max barra filettata  
Maximum tolerated projection  
of the threaded bar

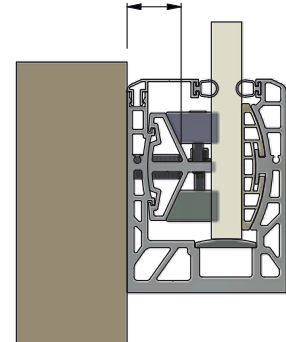

### TGS 603

Supporto di fissaggio fronte soletta in barra da 6000 mm  
Per vetri stratificati e temperati da 8+1.52+8 / 10+1.52+10 / 12+1.52+12  
Trasporto a cura del cliente

*Front wall fixing support, 6000 mm bar length. For 8+1.52+8 / 10+1.52+10 / 12+1.52+10 stratified and tempered glass. Transport borne by the customer*

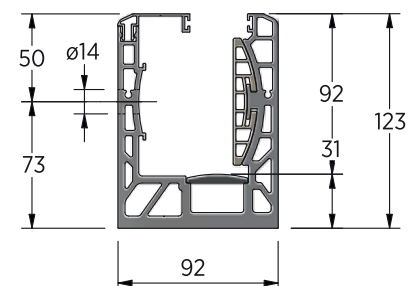
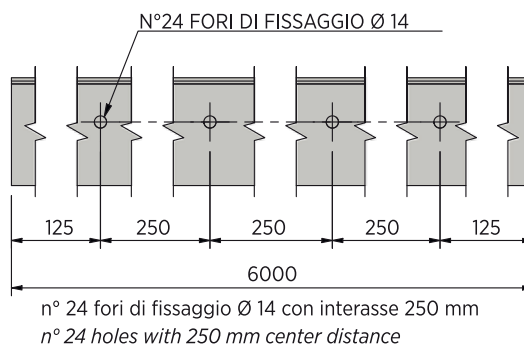

### TGS 604

Tappo per supporti a pavimento

*Floor supports side plug*

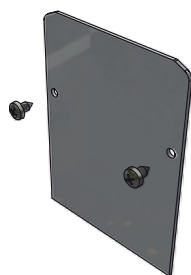

### TGS 205

Profilo scarico acque per supporti a pavimento.  
Lunghezza profilo 3000 mm  
Per TGS200-TGS600

*Water exhaust profile for floor fixed supports.*

*Profile length 3000 mm  
For TGS200-TGS600*

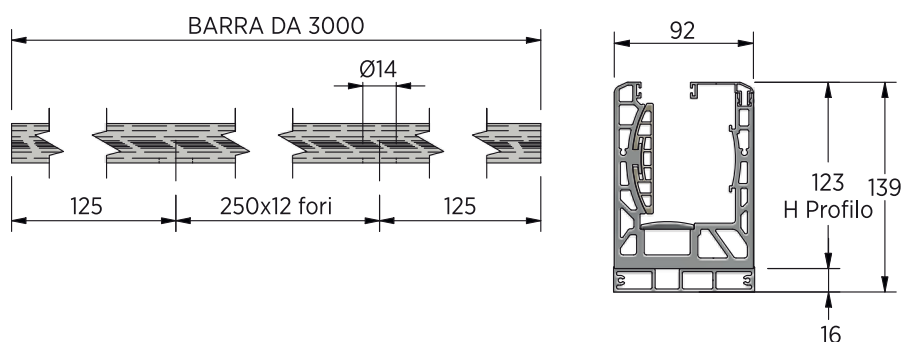

### TGS 206

Profilo scarico acque per supporti a pavimento.  
Lunghezza profilo 6000 mm  
Per TGS200-TGS600

Trasporto a cura del cliente

*Water exhaust profile for floor fixed supports.*

*Profile length 6000 mm  
For TGS200 - TGS600  
Transport borne by the customer*

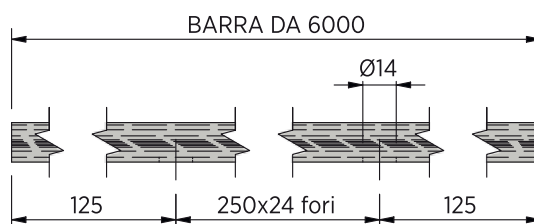
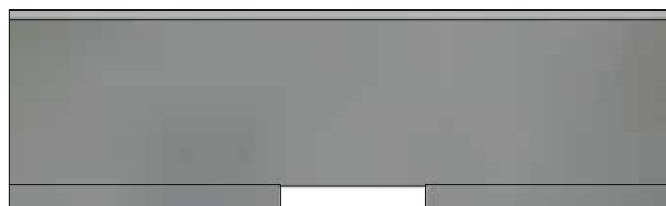

### TGS 207

Tappo per profili scarico acque

*Water exhaust profile plug*

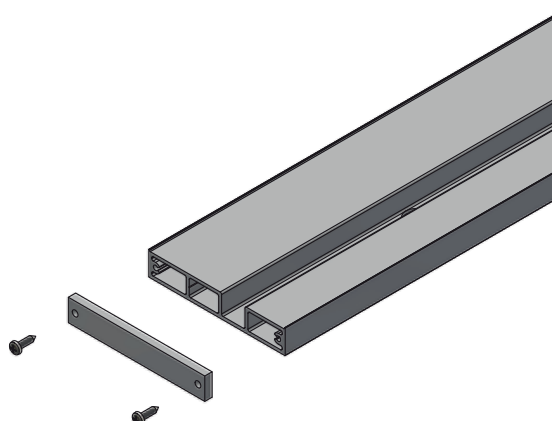

## SERIE TGS 700

### FILO SOLETTA/INCASSO SLAB/EMBEDDING THREAD

Sistema con fissaggio a filo soletta o ad incasso per vetro 8+1.52+8 e 10+1.52+10

*Profile bars for fastening flush or recessed for glass 8+1.52+8 and 10+1.52+10*

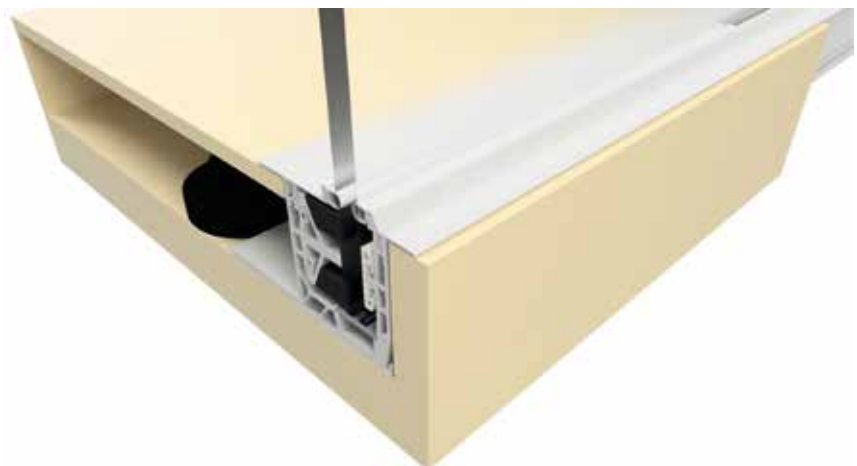
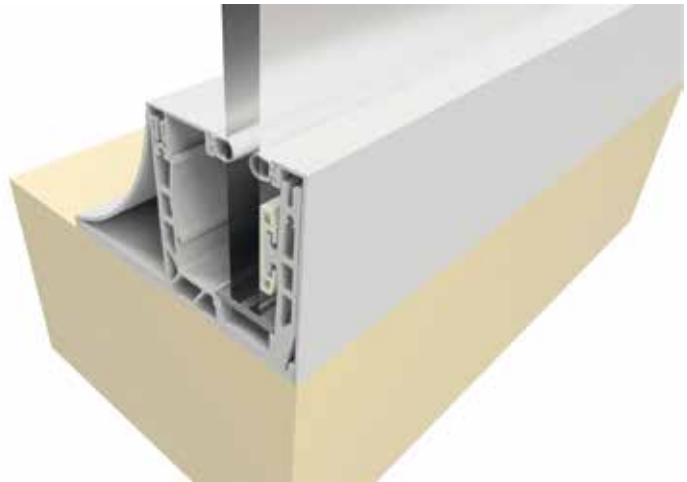
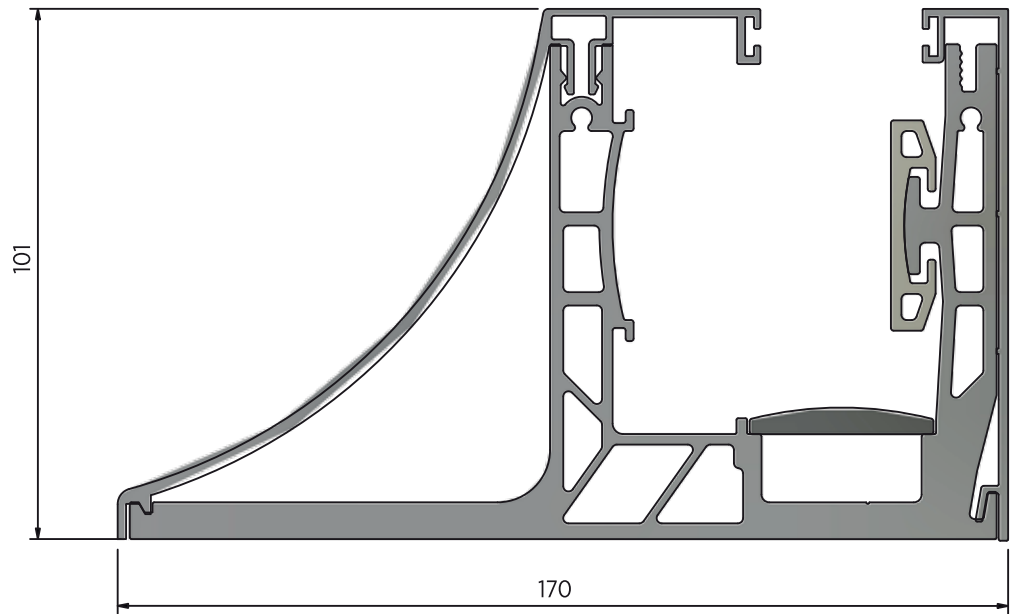

RAPPORTO DI PROVA  
TEST REPORT





### TGS 700

Supporto di fissaggio a pavimento a filo soletta in barra da 3000 mm per vetri 8+1.52+8 / 10+1.52+10

*Floor fastening bracket flush with floor in 3000 mm bar for glazing 8+1.52.8 / 10+1.52+10*

21  
Sporgenza max barra filettata  
Maximum tolerated projection  
of the threaded bar

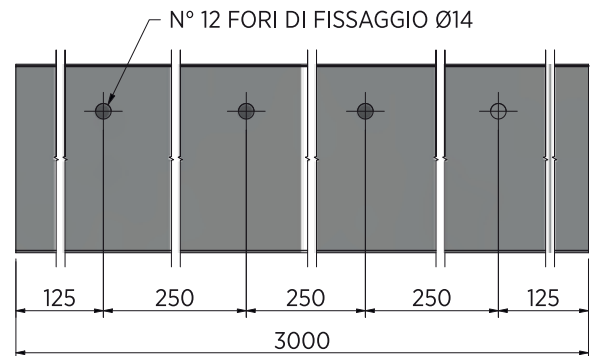
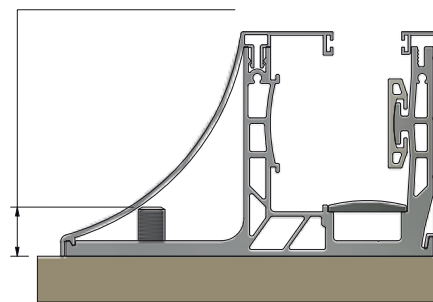

### TGS 701

Supporto di fissaggio a pavimento a filo soletta in barra da 6000 mm per vetri 8+1.52+8 / 10+1.52+10

*Floor fastening bracket flush with floor in 6000 mm bar for glazing 8+1.52.8 / 10+1.52+10*

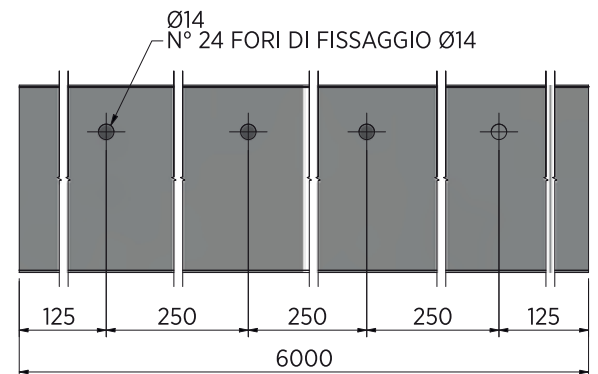
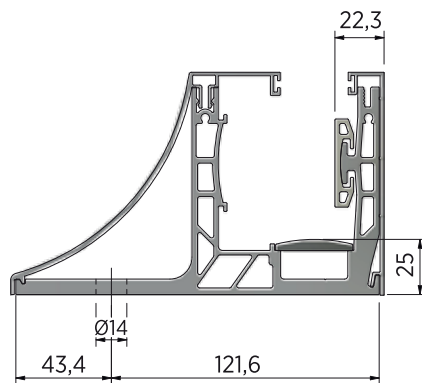

### TGS 702

Supporto di fissaggio ad incasso a filo soletta in barra da 3000 mm per vetri 8+1.52+8 / 10+1.52+10

*Recessed fixing bracket flush with slab in 3000 mm bar for glazing 8+1.52.8 / 10+1.52+10*

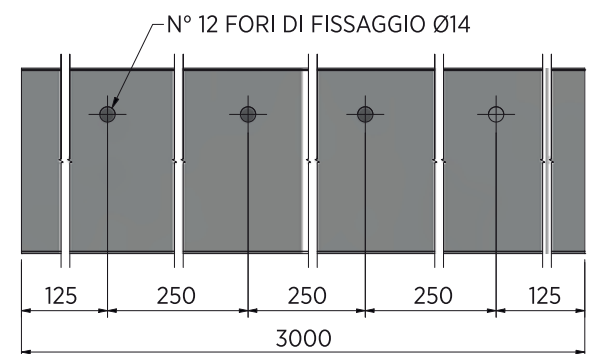
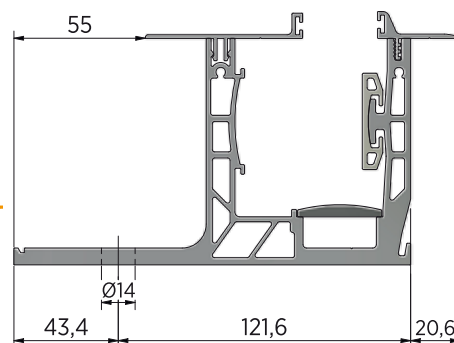

### TGS 703

Supporto di fissaggio ad incasso a filo soletta in barra da 6000 mm per vetri 8+1.52+8 / 10+1.52+10

*Recessed fixing bracket flush with slab in 6000 mm bar for glazing 8+1.52.8 / 10+1.52+10*

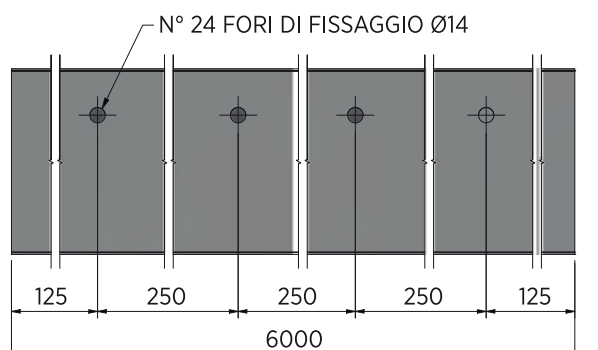

**TGS 704**

Tappo laterale per  
TGS700 - TGS701

Side cap for  
TGS700 - TGS701

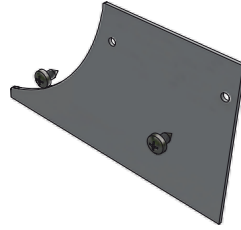

**ESEMPI DI APPLICAZIONE**  
*EXAMPLES OF APPLICATION*

**APPLICAZIONE A FILO SOLETTA**

*FLUSH SLAB APPLICATION*

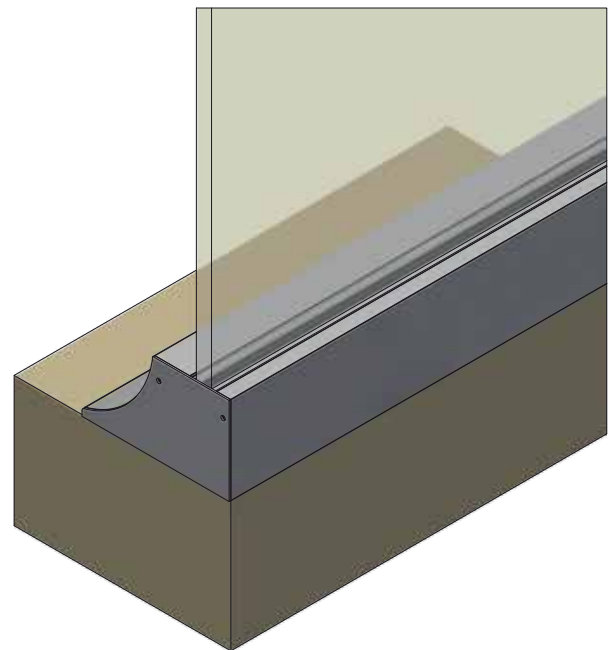

**APPLICAZIONE AD INCASSO**  
(INDICATA PER INSTALLAZIONE  
SU PAVIMENTO GALLEGGIANTE)

*RECESSED APPLICATION*  
(SUITABLE FOR INSTALLATIO  
ON FLOATING FLOOR)

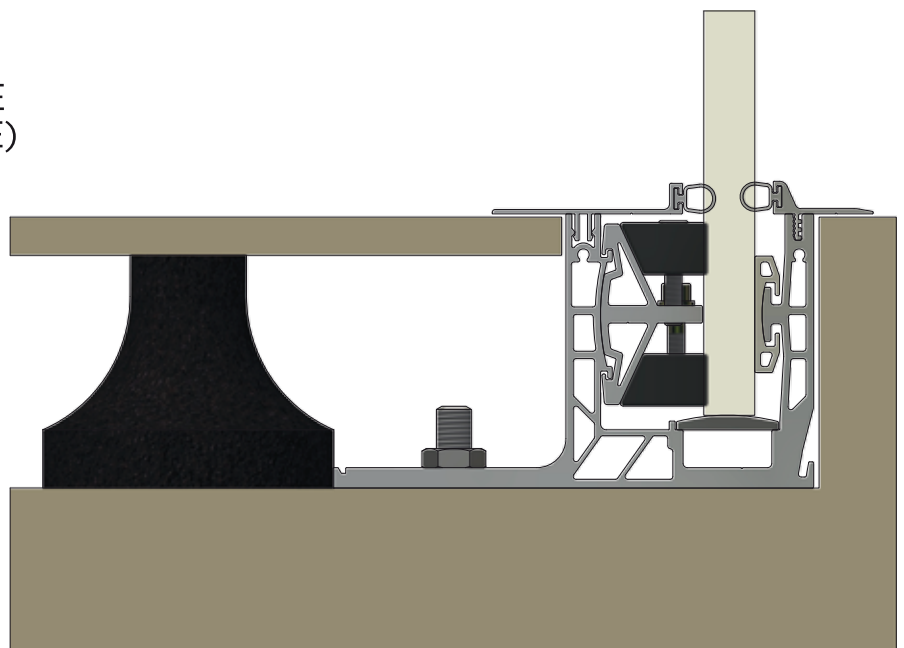



## SERIE TG 300

### SISTEMA A BLOCCHETTI PER FISSAGGIO A PAVIMENTO PROFILE BARS FOR FLOOR FIXING WITH BLOCKS

Sistema con fissaggio a pavimento a blocchetti per vetro  
8+1.52+8 / 10+1.52+10  
certificato 2 e 3 kN/m

Profile bars for floor fixing with blocks for  
8+1.52+8 / 10+1.52+10 glass  
tested for 2 and 3 kN/m

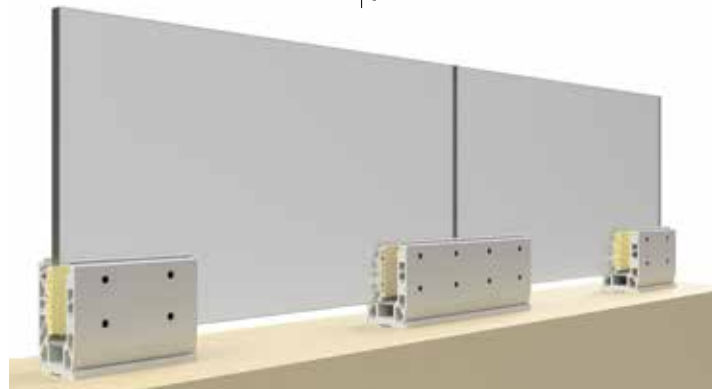
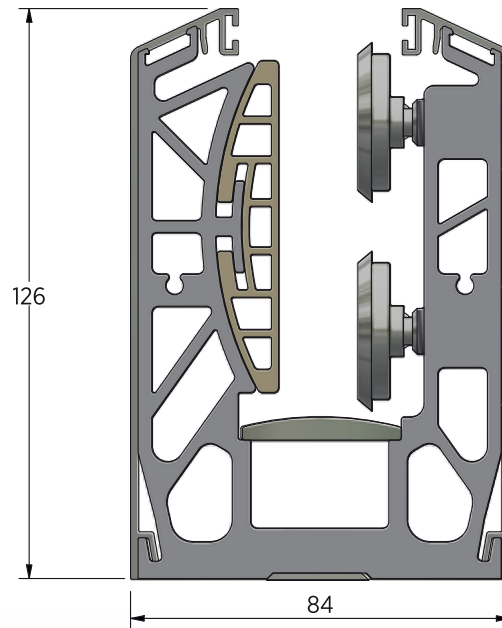

SISTEMA CON  
CARTER DI COPERTURA

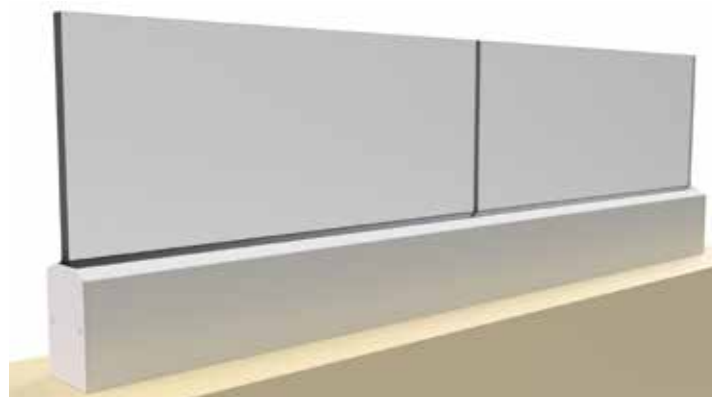

RAPPORTO DI PROVA  
TEST REPORT



### TG 300

Supporto di fissaggio a pavimento

*Floor fixing support*

Per vetri stratificati e temperati da mm 16 a 20

*For tempered laminated glass with a thickness between 16 and 20 mm*

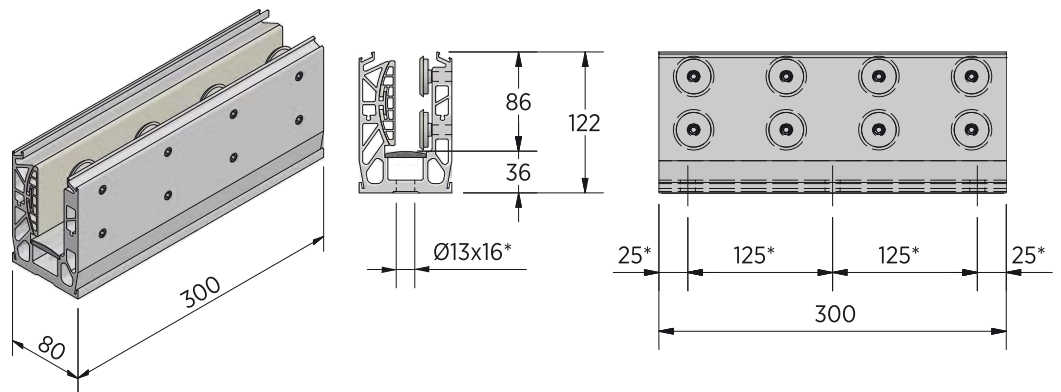

\*Diametro e interasse fori di fissaggio

*\*Fixing holes diameter and spacing*

### TG 323

Dima di foratura per TG 300

*Drilling template for TG 300*

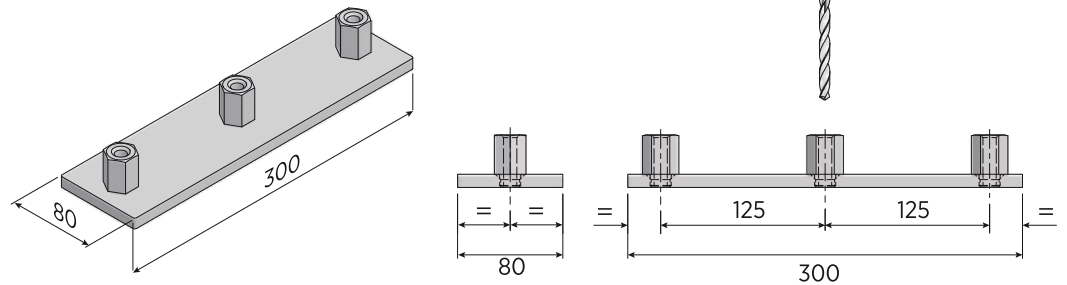

\*Foro di preparazione e riferimento

*\*Preparation and reference hole*

### TG 325

Supporto di fissaggio a pavimento

*Floor fixing support*

Per vetri stratificati da mm 16 a 20

*For tempered laminated glass with a thickness between 16 and 20 mm*

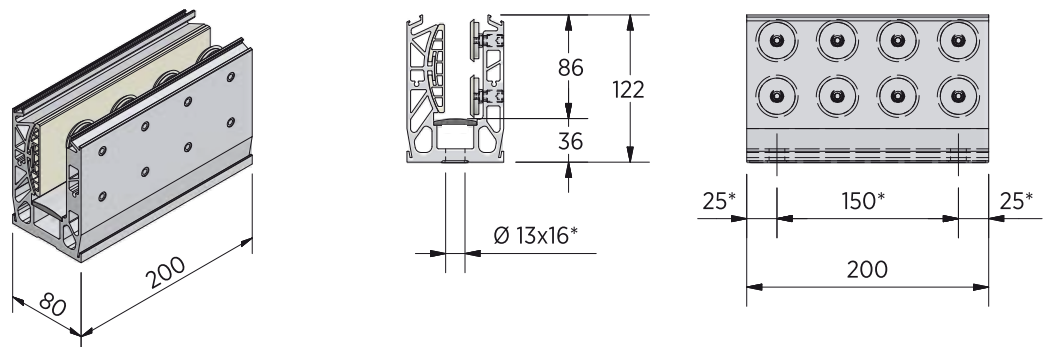

\*Diametro e interasse fori di fissaggio

*\*Fixing holes diameter and spacing*

### TG 327

Dima di foratura per TG 325 / TG 600

*Drilling template for TG 325 / TG 600*

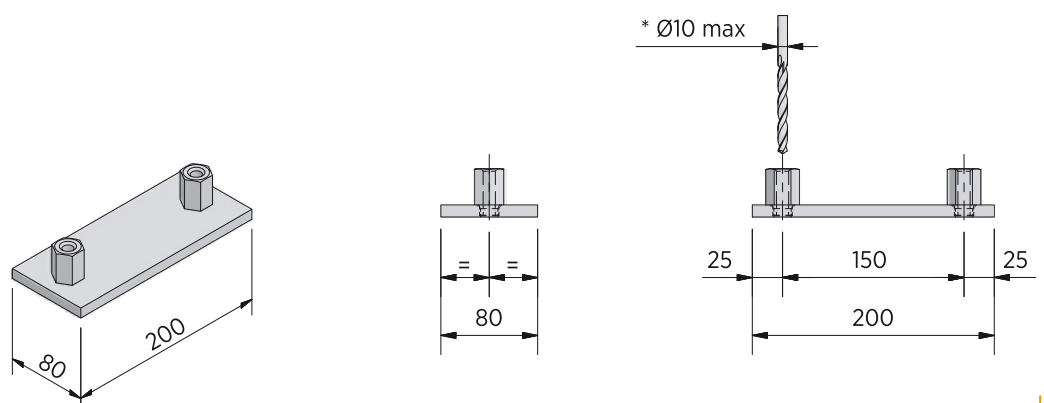

\*Foro di preparazione e riferimento

*\*Preparation and reference hole*

### TG 301

Supporto di fissaggio a pavimento

*Floor fixing support*

Per vetri stratificati e temperati da mm 16 a 20

*For tempered laminated glass with a thickness between 16 and 20 mm*

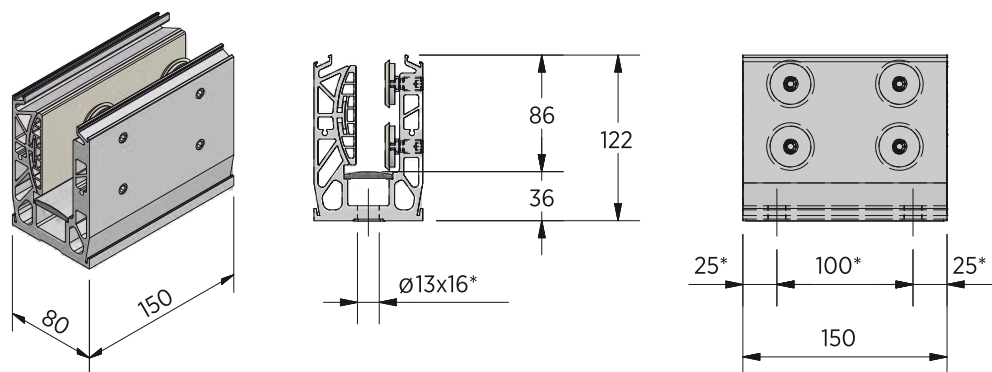

\*Diametro e interasse fori di fissaggio

*\*Fixing holes diameter and spacing*

### TG 324

Dima di foratura per TG 301

*Drilling template for TG 301*

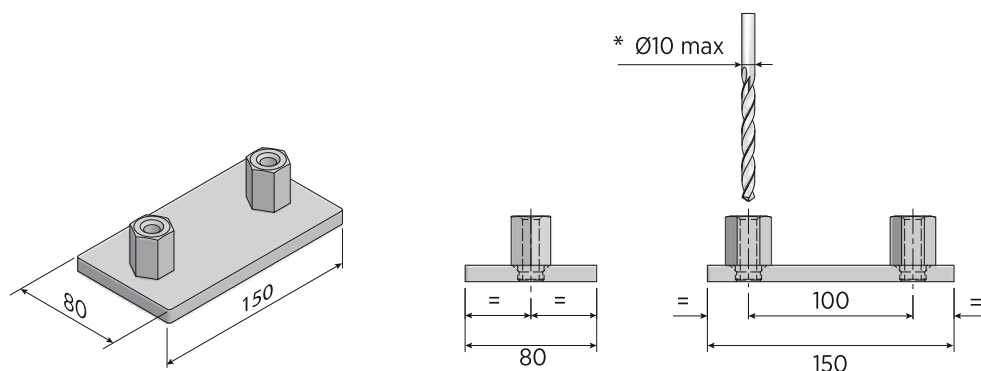

\*Foro di preparazione e riferimento

*\*Preparation and reference hole*

### TG 326

Supporto di fissaggio a pavimento

*Floor fixing support*

Per vetri stratificati da mm 16 a 20

*For tempered laminated glass with a thickness between 16 and 20 mm*

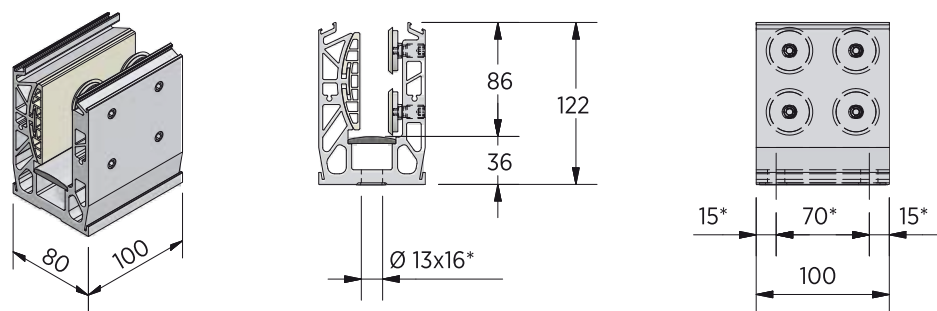

\*Diametro e interasse fori di fissaggio

*\*Fixing holes diameter and spacing*

### TG 328

Dima di foratura per TG 326 / TG 601

*Drilling template for TG 326 / TG 601*

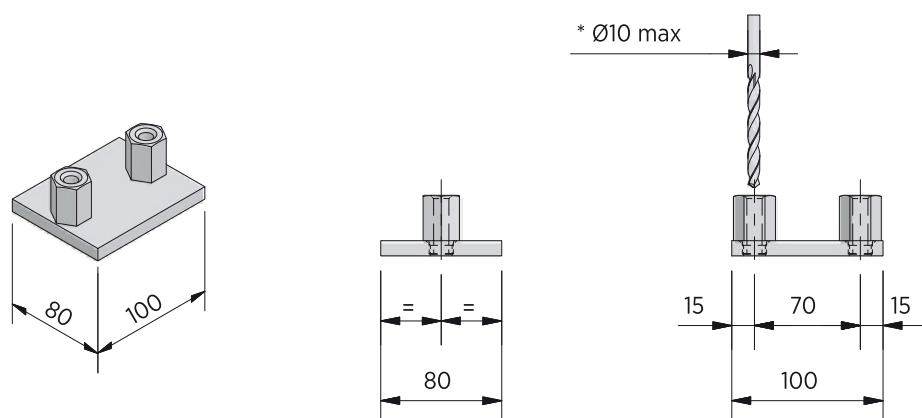

\*Foro di preparazione e riferimento

*\*Preparation and reference hole*

### TG 319

Angolo a 90° esterno  
External 90° corner

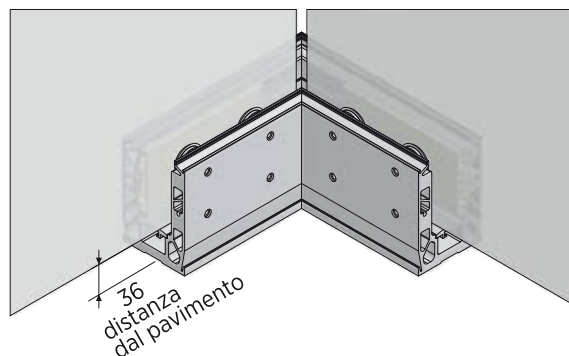
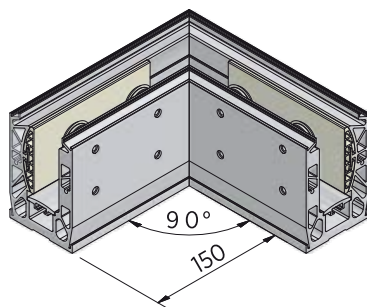

### TG 320

Angolo a 90° interno  
Internal 90° corner

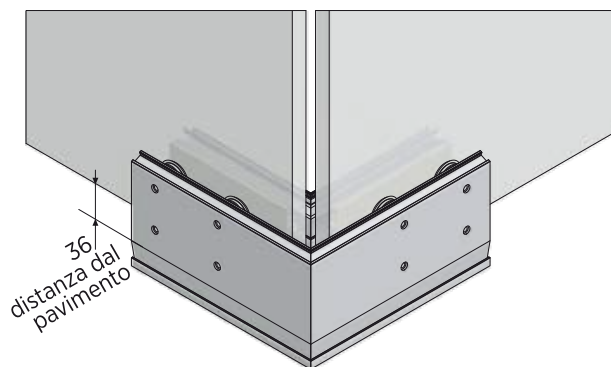
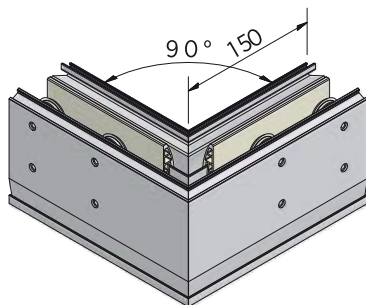

### TG 308

Copertella laterale  
• Trasporto a cura del cliente  
Side cover  
• Transport by the customer

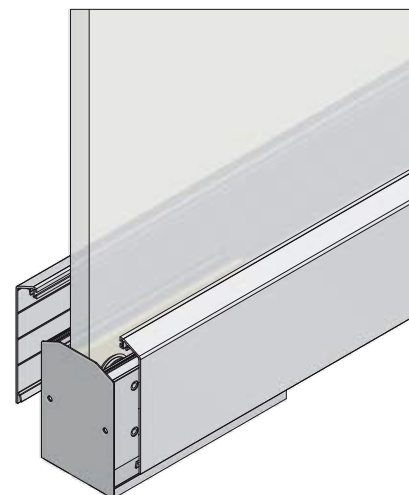
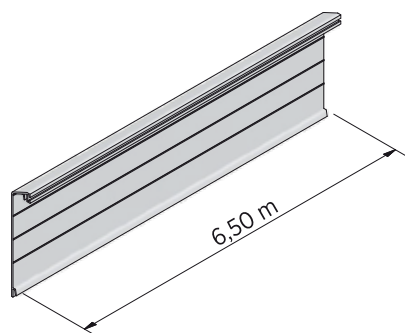

### TG 312

Copertella laterale  
Side cover

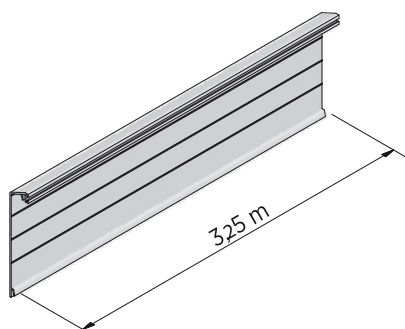

### TG 303

Sistema di scarico acque piovane

*Drain water discharge*

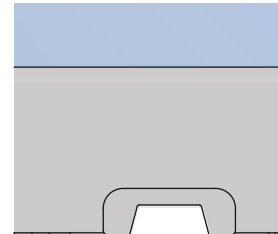
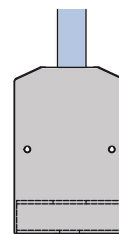
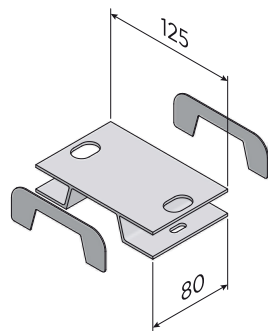

Eeguire intaglio rettangolare di dimensioni 65mm x 25mm sul profilo del carter

*Perform a rectangular cut sized 65mm x 25mm on the crankcase outline*

### TG 302

Tappo laterale

*Side cap*

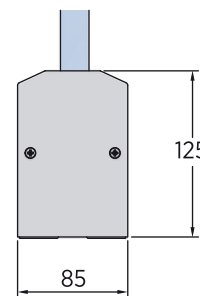
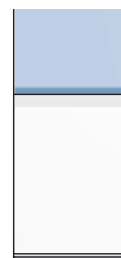
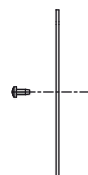
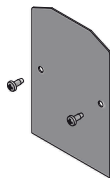



ACCESSORI E PROFILATI | ACCESSORIES AND PROFILES

1.

Tracciare una linea retta sulla quale verranno praticati i fori per il passaggio dei supporti.  
Forare secondo le misure riportate in figura, quindi applicare le barre filettate.  
Infilare nelle barre filettate le guarnizioni fornite con gli accessori TG 300 e TG 301

*Draw a straight line on which can be drilled the holes for bracket fastening.  
Drill a hole according to the measures indicated in the figure, then apply the threaded rods. Insert the seals in the threaded rods with the accessories TG 300 and TG 301.*

Esempio utile alla realizzazione di un'installazione idonea ad accogliere un vetro di lunghezza pari a 1.2 m sfruttando n. 1 supporto TG 300 posto al centro del vetro e n. 2 supporti TG 301 posti all'estremità; per installazioni con più vetri si fa sempre riferimento alle misure riportate, applicando però gli interassi di TG 300 per ogni supporto intermedio.

*Useful example to realize a suitable installation for accommodating a piece of glass 1.2 m in length using a TG 300 support placed at the center of the piece itself and two TG 301 supports placed at its ends. The measures indicated have to be applied also for installations with more than one piece of glass, but using the interaxle spacing of TG 300 for every intermediate support.*

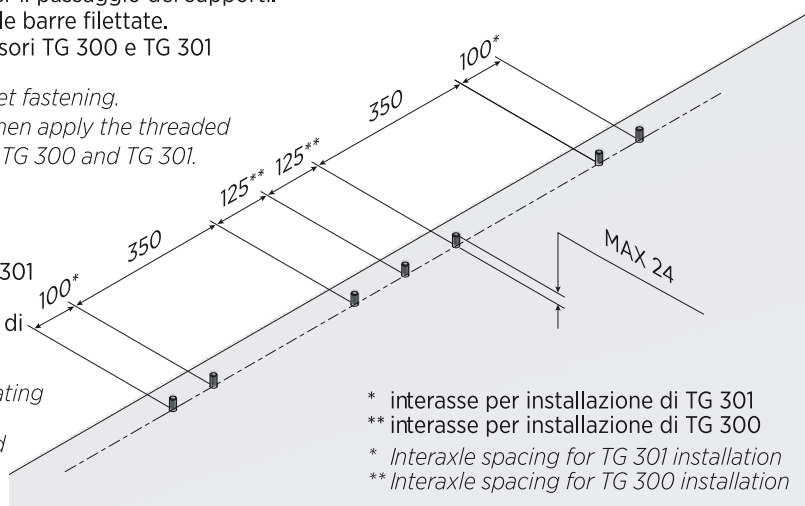

Possibilità di utilizzo dime TG 323 e TG 324 per una foratura immediata

*Possibility to use TG 323 and TG 324 templates for immediate drilling*

2.

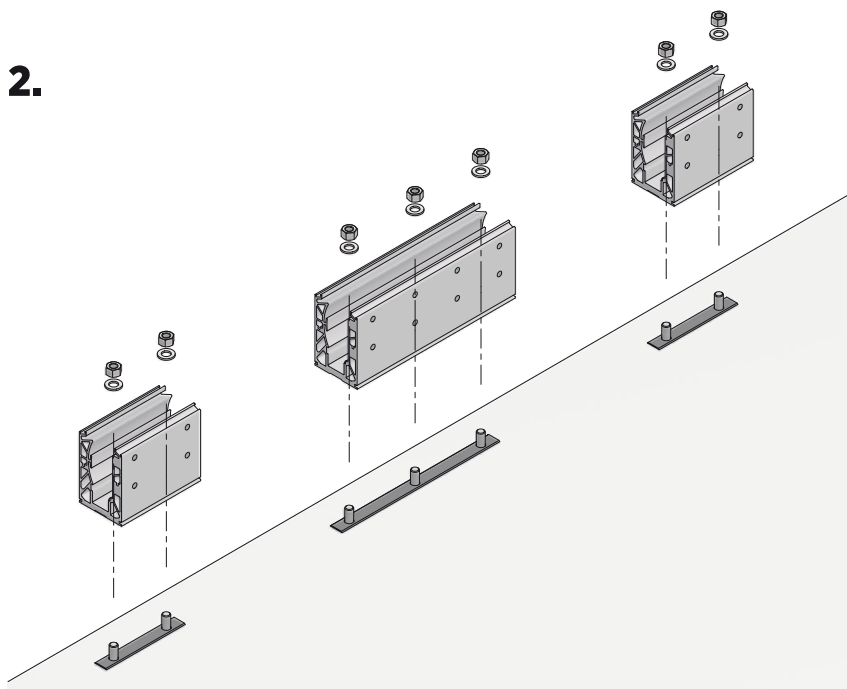

Fissare gli accessori TG 300 e TG 301 alla pavimentazione

*Fasten the accessories TG 300 and TG 301 to the floor*

3.

Agganciare la copertella posteriore completa di apposita guarnizione ed inserire nelle apposite sedi il poggivetro in policarbonato trasparente\* e l'appoggio laterale in abs, infine avvitare in senso antiorario fino a battuta i grani completi di piattelli in nylon (4 per TG 301, 8 per TG 300)

*Fasten posterior cover with the specific seal and insert the glass supporting tables in transparent polycarbonate and the lateral supports in abs in their specific seats, then fasten the plates in nylon by fully screwing counterclockwise grub screws (4 rounds for TG 301, 8 rounds for TG 300)*

\*Nei casi in cui è previsto il montaggio del sistema con illuminazione a led il poggivetro in policarbonato sarà composto da un unico pezzo di lunghezza pari a quella dell'installazione

*\*In the cases in which assembling of the lighting system with LED support has to be performed, the glass supporting table in transparent polycarbonate will be composed by a single piece of length equal to that of the installation.*

TG 311 - TG 313

Se non si monta il sistema LED il segmento di policarbonato di lunghezza pari al supporto TG 300 e TG 301 è incluso nell'accessorio

*If the LED system is not mounted, the segment in polycarbonate of length equal to the TG 300 and TG 301 support is included in the accessory.*



Piattello basculante che segue l'inclinazione del vetro

*The tilting and self-stabilizing plate following the glass inclination*

ACCESSORI E PROFILATI | ACCESSORIES AND PROFILES

4.

Inserire il vetro e regolare la posizione utilizzando i piattelli in nylon autorientanti, infine bloccare mediante i grani \*

*Insert the piece of glass and adjust position using the self-orienting plates in nylon, then block using grub screws \**



N.B.: il criterio di certificazione è rispettato se almeno il 50% della lunghezza totale dell'installazione è supportato dagli accessori TG 300 e TG 301

*N.B.: the certification criterion is respected if at least 50% of total length of the installation is supported by TG 300 and TG 301 accessories*

Esempio per modulo da 1200mm:  
TG 301 (150mm) + TG 300 (300mm) + TG 301 (150mm) = 600mm

*Example for 1200 mm module:  
TG 301 (150mm) + TG 300 (300mm) + TG 301 (150mm) = 600mm*

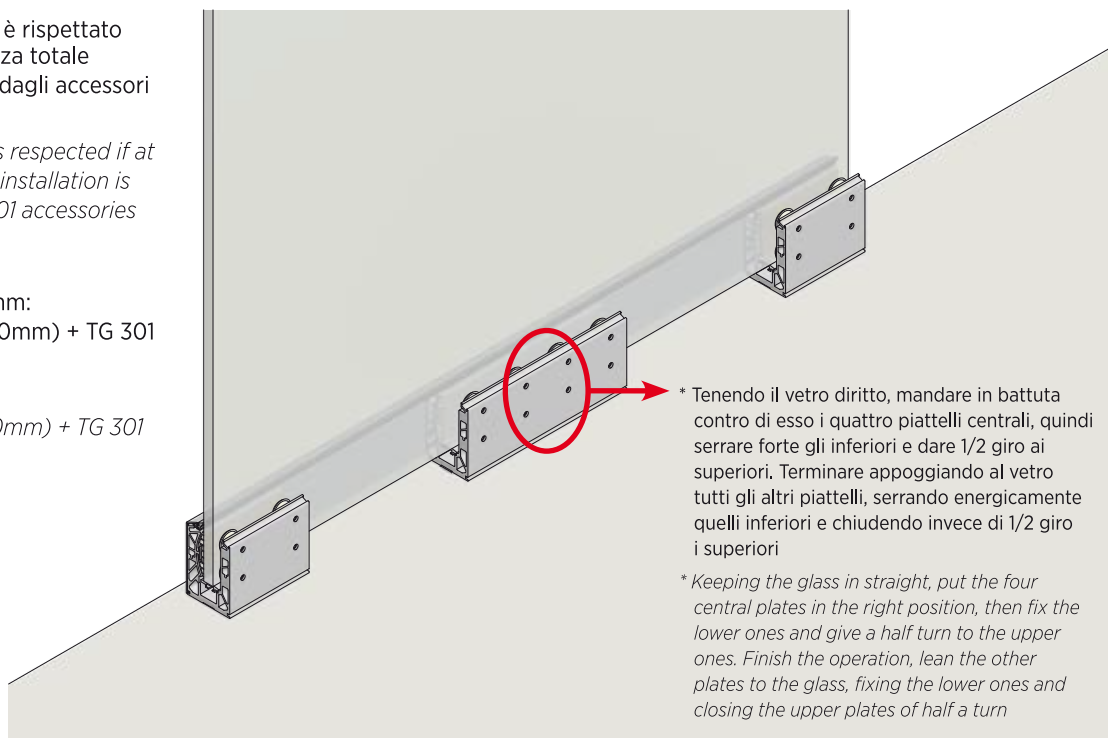

5.

Agganciare la copertella anteriore completa di guarnizione e fissare i tappi laterali. Qualora per mancanza di spazio laterale non sia possibile avvitare le viti dei tappi in quest'ultima fase, montarli prima della fase 1 dopo aver inserito i vari accessori (mezzaluna, guarnizione, piattelli)

*Fasten front cover with its specific seal and lock lateral caps. If due to lack of lateral space it is not possible to screw the screws of the caps as last step, mount them before phase 1 after inserting the various accessories (half-moon side profile, gasket, locking plates)*

A garanzia di maggiore impermeabilità, siliconare il bordo inferiore della copertella interna.

*To guarantee a better impermeability, siliconize the lower edge of the internal cover*

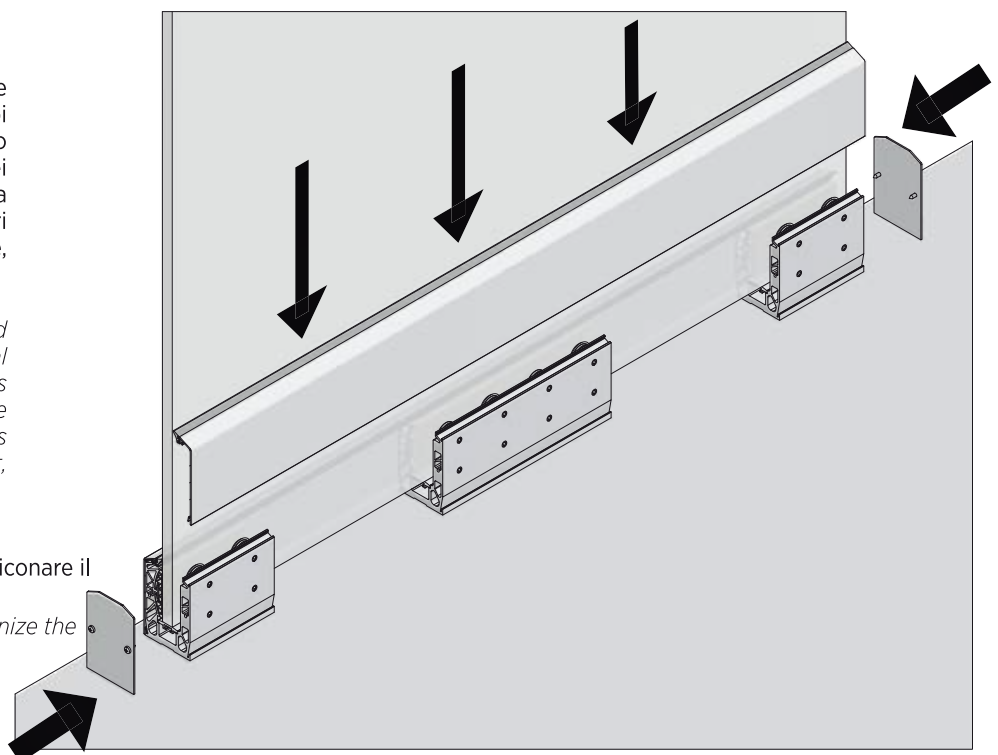

SERIE TG 400

SISTEMA A BLOCCHETTI PER FISSAGGIO FRONTE SOLETTA  
PROFILE BARS FOR FLOOR FIXING WALL FIXING WITH BLOCKS

Sistema con fissaggio  
fronte soletta a blocchetti  
per vetro 8+1.52+8 / 10+1.52+10  
certificato 2 e 3 kN/m

Profile bars for floor fixing  
wall fixing with blocks  
8+1.52+8 / 10+1.52+10 glass  
tested for 2 and 3 kN/m

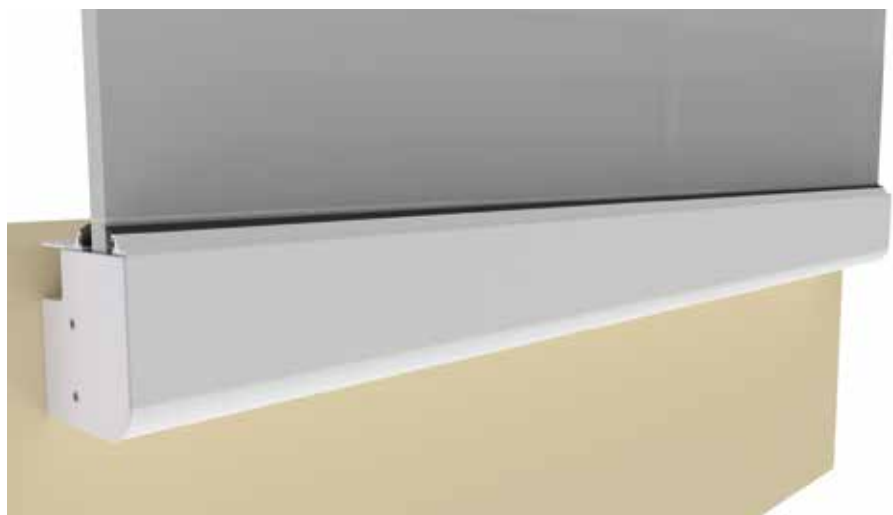
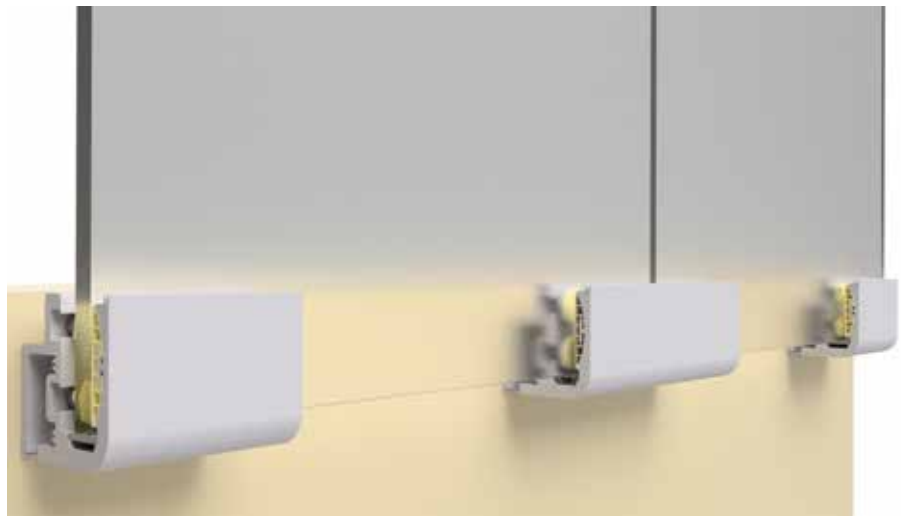
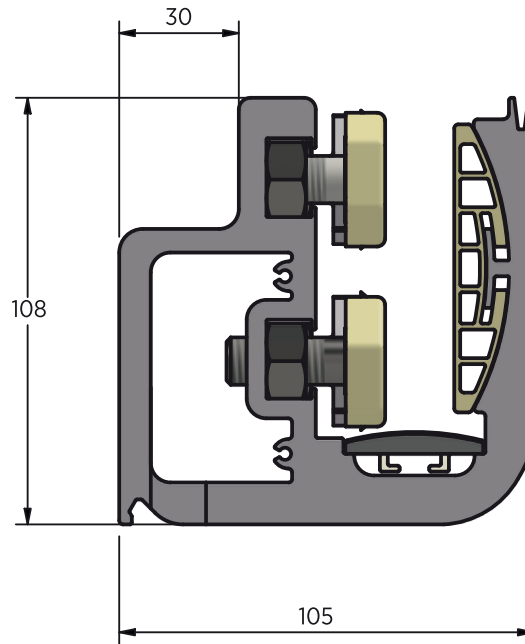

RAPPORTO DI PROVA  
TEST REPORT



ACCESSORI E PROFILATI | ACCESSORIES AND PROFILES

**TG 400**

Supporto di fissaggio fronte soletta

- per vetri da mm 17,52

*Front base fixing support*

- for glasses of 17,52 mm

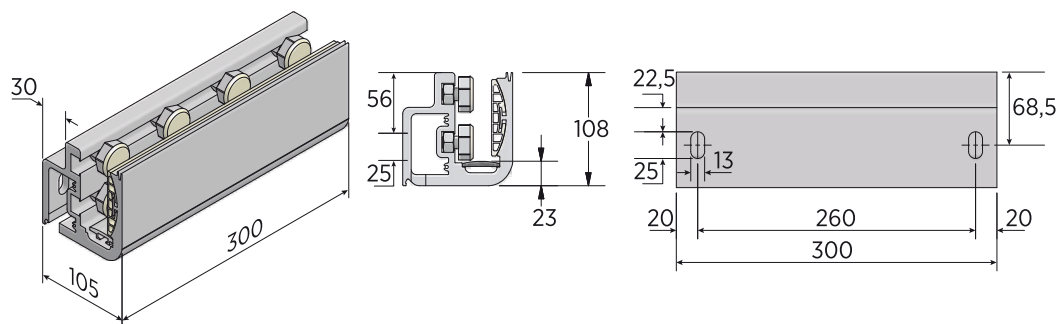

**TG 402**

Supporto di fissaggio fronte soletta

- per vetri da mm 21,52

*Front base fixing support*

- for glasses of 21,52 mm

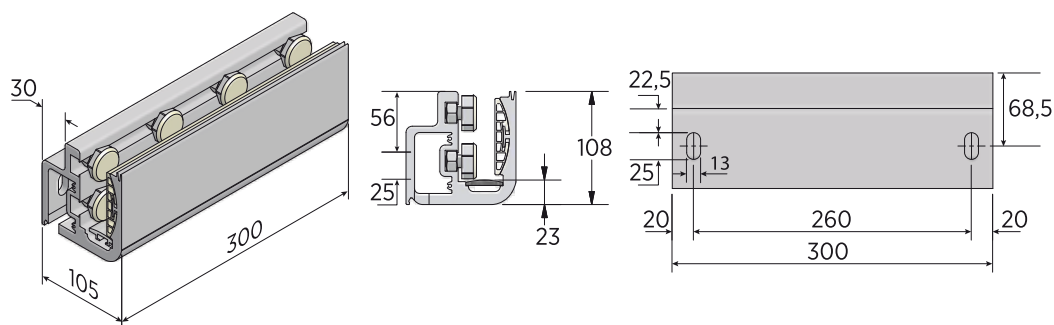

**TG 414**

Dima di foratura

- per TG 400 e TG 402

*Drilling template*

- for TG 400 and TG 402

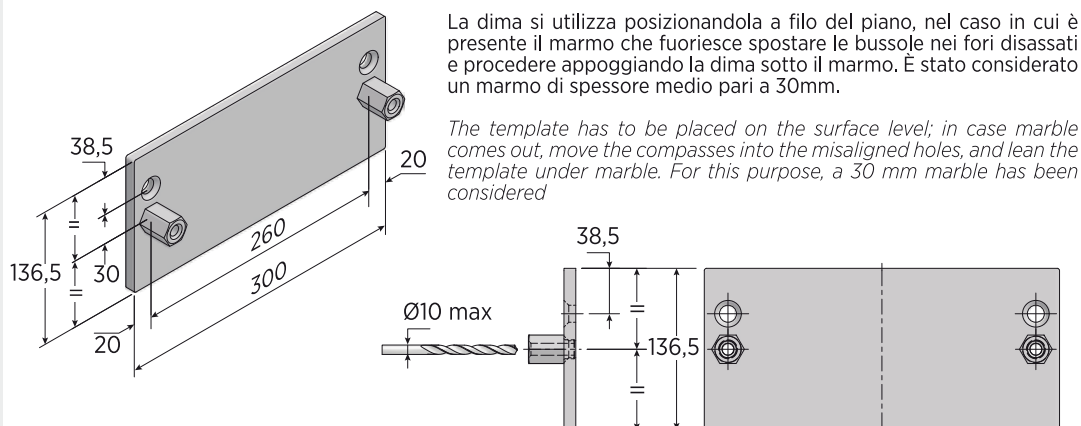

**TG 401**

Supporto di fissaggio fronte soletta

- per vetri da mm 17,52

*Front base fixing support*

- for glasses of 17,52 mm

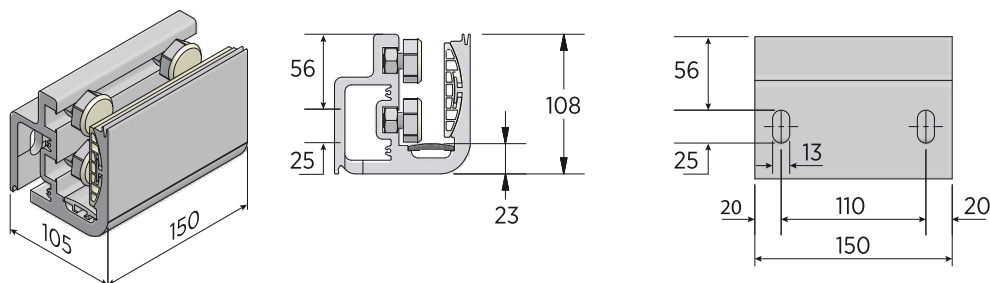

**TG 403**

Supporto di fissaggio fronte soletta

- per vetri da mm 21,52

*Front base fixing support*

- for glasses of 21,52 mm

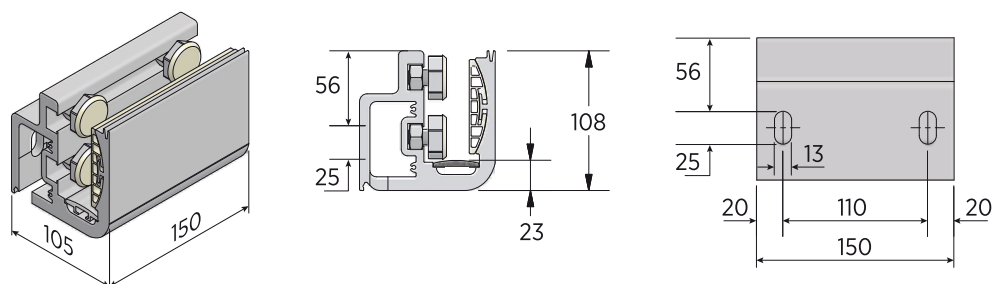

ACCESSORI E PROFILATI | ACCESSORIES AND PROFILES

**TG 415**

Dima di foratura

- per TG 401 e TG 403

Drilling template

- for TG 401 and TG 403

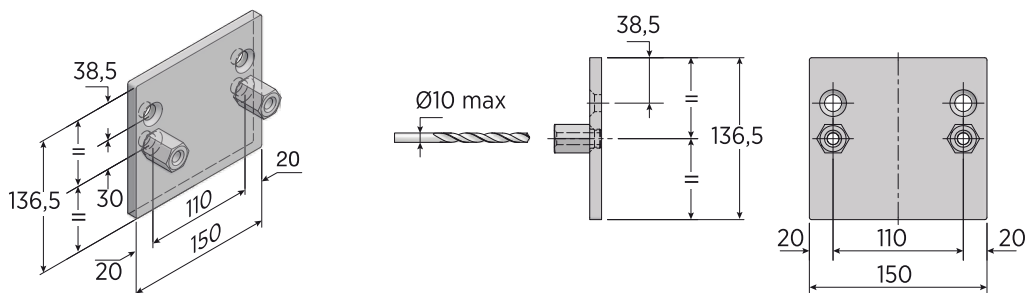

La dima si utilizza posizionandola a filo del piano, nel caso in cui è presente il marmo che fuoriesce spostare le bussole nei fori disassati e procedere appoggiando la dima sotto il marmo. È stato considerato un marmo di spessore medio pari a 30mm.

*The template has to be placed on the surface level; in case marble comes out, move the compasses into the misaligned holes, and lean the template under marble. For this purpose, a 30 mm marble has been considered.*

**TG 404 DX**

Tappo destro

- per supporti TG 400, TG 401, TG 402 e TG 403

Right Cup

- for TG 400, TG 401, TG 402 and TG 403.

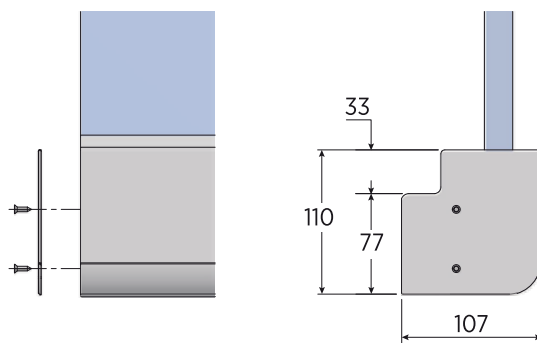
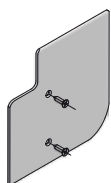

**TG 404 SX**

Tappo destro

- per supporti TG 400, TG 401, TG 402 e TG 403

Right Cup

- for TG 400, TG 401, TG 402 and TG 403.

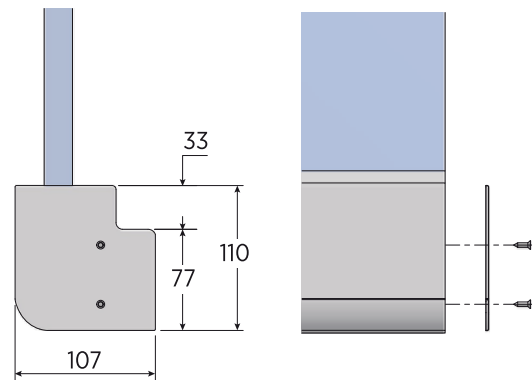

**TG 405**

Copertella frontale

- barra da 3,25 m

Front cover

- 3,25 m bar

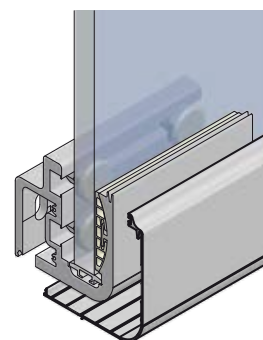
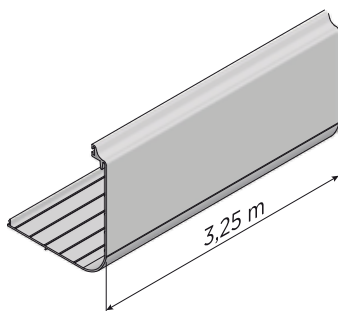

**TG 406**

Copertella frontale

- barra da 6,5 m
- trasporto a cura del cliente

Front cover

- 6,5 m bar
- Transport by the customer

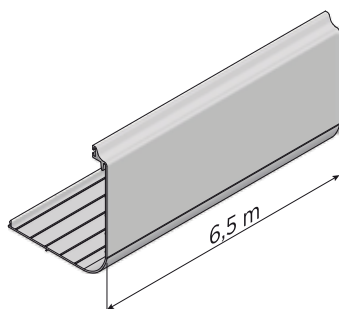

Attenzione: la copertella va sempre fissata con vite autofilettante in corrispondenza dell'accessorio e della tacca di posizione presente sul profilo della copertella.

*Caution: the cover must be fixed with self-tapping screws in correspondence of the accessory and the position notch on the cover profile.*

ACCESSORI E PROFILATI | ACCESSORIES AND PROFILES

**TG 407**

Copertella piano balcone

- barra da 3,25 m

*Balcony cover*

- 3,25 m bar

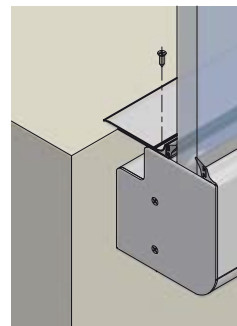
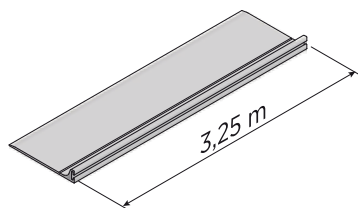

**TG 408**

Copertella piano balcone

- barra da 6,5 m
- trasporto a cura del cliente

*Balcony cover*

- 6,5 m bar
- Transport by the customer

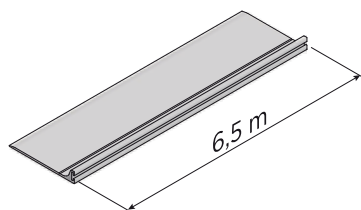

Attenzione: la copertella va sempre fissata con vite autofilettante in corrispondenza dell'accessorio e della tacca di posizione presente sul profilo della copertella.

*Caution: the cover must be fixed with self-tapping screws in correspondence of the accessory and the position notch on the cover profile.*



ACCESSORI E PROFILATI | ACCESSORIES AND PROFILES

**TG 410**

Supporto inclinato 30° DX  
 • per vetri di spessore 17,52 mm  
*Right 30° inclined support*  
 • for 17,52 mm thick glass

\* Spessore vetri  
 \* Glass thickness

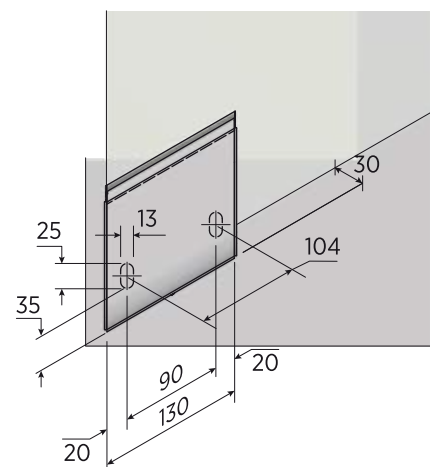
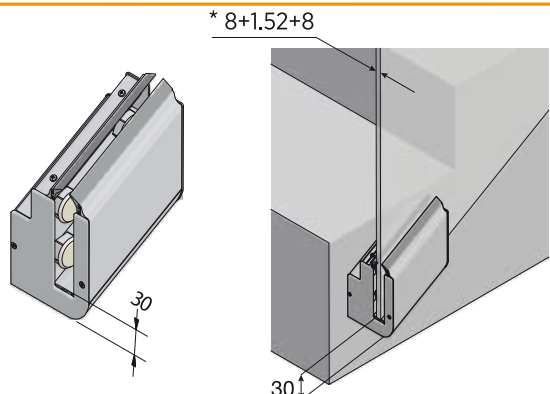

Disponibile dima di Foratura cod. TG 417  
 Drill Template available, cod. TG 417

**TG 412**

Supporto inclinato 30° DX  
 • per vetri di spessore 21,52 mm  
*Right 30° inclined support*  
 • for 21,52 mm thick glass

\* Spessore vetri  
 \* Glass thickness

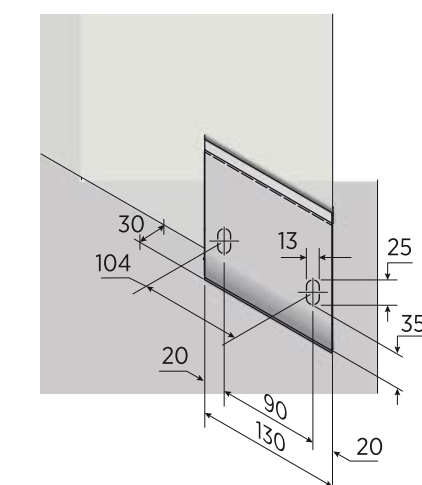
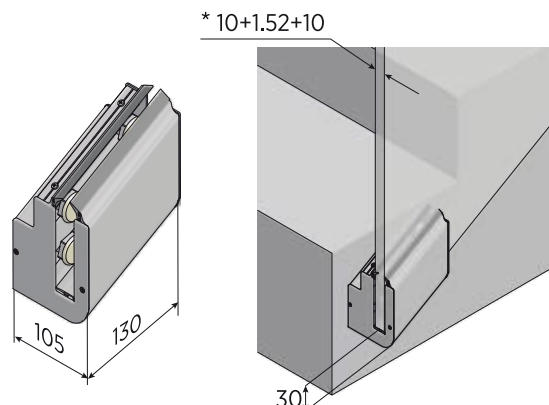

Disponibile dima di Foratura cod. TG 418  
 Drill Template available, cod. TG 418

**TG 411**

Supporto inclinato 30° SX  
 • per vetri di spessore 17,52 mm  
*Left 30° inclined support*  
 • for 17,52 mm thick glass

\* Spessore vetri  
 \* Glass thickness

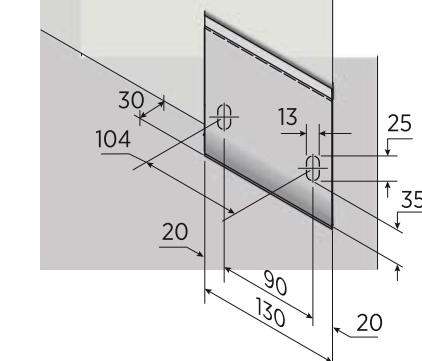
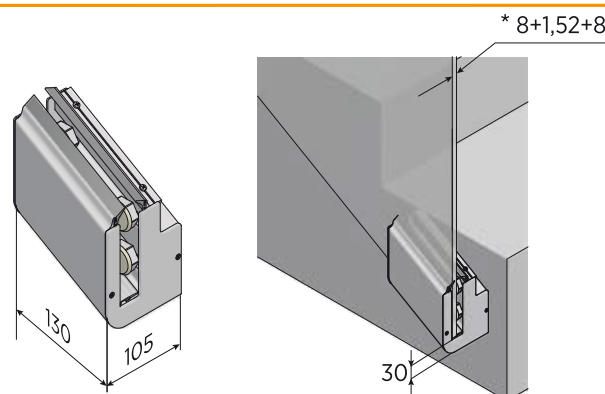

Disponibile dima di Foratura cod. TG 418  
 Drill Template available, cod. TG 418

**TG 413**

Supporto inclinato 30° SX  
 • per vetri di spessore 21,52 mm  
*Left 30° inclined support*  
 • for 21,52 mm thick glass

\* Spessore vetri  
 \* Glass thickness

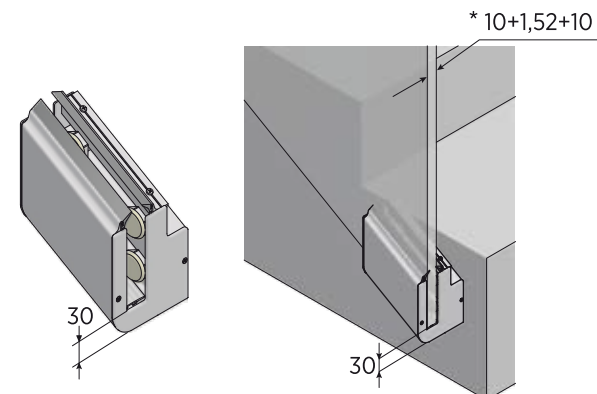

\* Misura scarico vetro  
 Si consiglia scarico al centro del vetro  
 \* Glass hollow size  
 Hollowin in the center of the glass is recommended

**TG 416**

Fermavetro in policarbonato nero  
 • per TG 410, 411, 412, 413  
*Polycarbonate glazing beads*  
 • for TG 410, 411, 412, 413

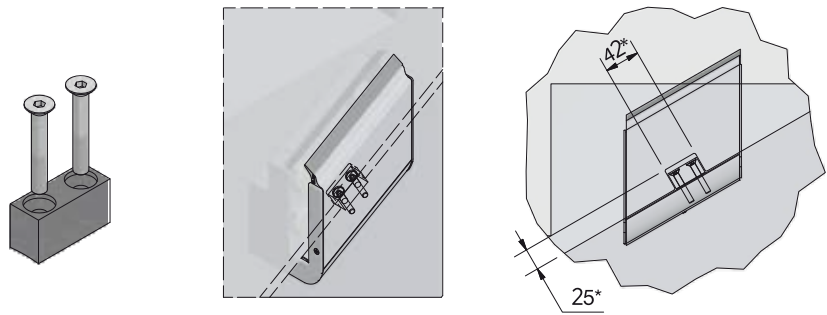

ISTRUZIONI DI MONTAGGIO | ASSEMBLY AND PROFILES

MONTAGGIO FRONTE SOLETTA - BALCONI | FRONT BASE ASSEMBLY - BALCONY

1.

In assenza di marmo sporgente posizionare le dime a filo del pavimento e forare utilizzando i fori centrali rispettando le corrette distanze tra i supporti e seguire le linee guida riportate di seguito a seconda della tipologia di vostro interesse. Qualora vi sia il marmo sporgente usare i fori disassati delle dime.

*In absence of protruding marble, place the templates at the floor level and drill using the central holes and respecting the right distances between the supports. Then follow the guidelines below according to the desired type. In case of protruding marble, use the misaligned holes of the template.*

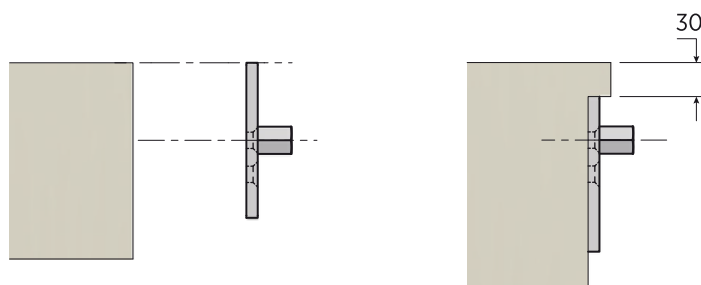

A filo pavimento usare i fori centrali (contrassegnati come fori "A")

*Use the central holes at the floor level (marked as "A" holes)*

In presenza di marmo appoggiarsi al piano inferiore del marmo e forare usando i fori disassati (contrassegnati come fori "B")

*In case of marble, lean against the lower marble surface and drill using the misaligned holes (marked as "B" holes)*

**A. DISPOSIZIONE SUPPORTI PER SOLUZIONE EDILIZIA PRIVATA (K g 300/mt. lin)**

*ARRANGEMENT OF SUPPORTS FOR PRIVATE BUILDING SOLUTIONS (Kg 200/linear meter)*

Il 50% della lunghezza totale dell'installazione deve essere coperta dai supporti.

Esempio per modulo base da 1200mm:

almeno 600 mm dovranno essere coperti da accessori.

Elenco Supporti e loro disposizione necessari per rispettare i criteri di certificazione:

- partenza con TG 401 (mm 150) • centrale TG 400 (mm 300)
- finale con TG 401 (mm 150)

150+300+150=600 mm (metà della lunghezza totale del modulo)

Usare sempre i supporti di lunghezza pari a 300 mm come unione tra due vetri, così si avrà la stessa inclinazione su tutti i vetri dell'installazione.

*50% of the total installation length should be covered by the supports.*

*Example for a basic 1200 mm module:*

*at least 600 mm shall be covered by the accessories.*

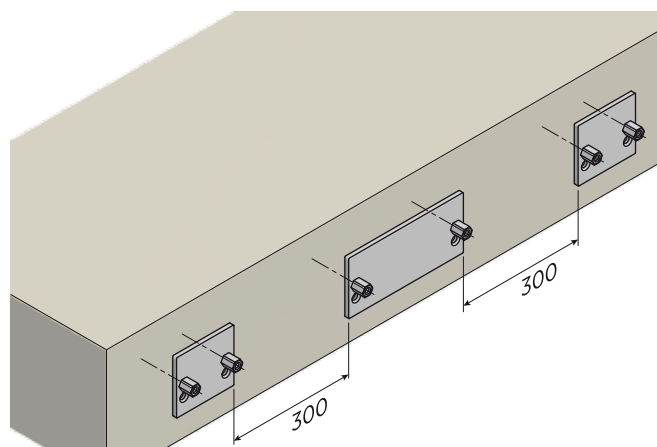

*List of supports and info on their arrangement.*

**The list is necessary to meet the certification criteria:**

- starting point with TG 401 (150 mm) • central TG 400 (300 mm)
- ending point with TG 401 (150 mm)

150+300+150=600 mm (half of the total module length)

*Always use the 300 mm long supports, as a union of two glasses, in order to obtain the same inclination on all the installation's glasses.*

**B. DISPOSIZIONE SUPPORTI PER SOLUZIONE EDILIZIA PUBBLICA (Kg 300/mt. lin)**

*ARRANGEMENT OF SUPPORTS FOR PRIVATE BUILDING SOLUTIONS (Kg 200/linear meter)*

3/4 della lunghezza totale dell'installazione deve essere coperta dai supporti.

Esempio per modulo base da 1200mm:

almeno 900 mm dovranno essere coperti da supporti.

Elenco Supporti e loro disposizione necessari per rispettare i criteri di certificazione:

- partenza con TG 403 (mm 150)
- seguono n° 2 TG 402 (mm 300+300) • finale con TG 403 (mm 150)

150+300+300+150 = 900 mm (3/4 della lunghezza totale del modulo)

Usare sempre i supporti di lunghezza pari a 300 mm come unione tra due vetri, così si avrà la stessa inclinazione su tutti i vetri dell'installazione.

*3/4 of the total length of the installation shall be covered by the supports.*

*Example for a basic 1200 mm module:*

*At least 900 mm shall be covered by the supports.*

*List of the supports and info on their arrangement. The list is*

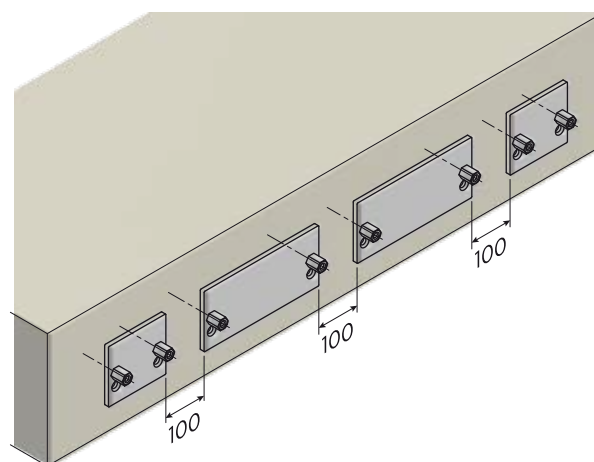

**necessary to meet the certification criteria:**

- starting point with TG 403 (150 mm)
- followed by N.2 TG 402 (300+300 mm)
- ending point with TG 403 (150 mm)

150+300+300+150=900 mm (3/4 of the total module's length)

*Always use the 300 mm long supports, as a union of two glasses, in order to obtain the same inclination on all the installation's glasses.*



ISTRUZIONI DI MONTAGGIO | ASSEMBLY AND PROFILES

2.

Posizionare le barre filettate e fissare gli accessori aiutandosi con l'apposita chiave e sfruttando le aperture laterali. Assicurarsi che il piano indicato in figura sia a filo della pavimentazione (operazione facilmente eseguibile aiutandosi con una squadra)

Place the bars, thread and fix the accessories using the specific key and the side openings. Make sure that the surface indicated in the picture is at the floor level (this operation is easy to be carried out using a set square)

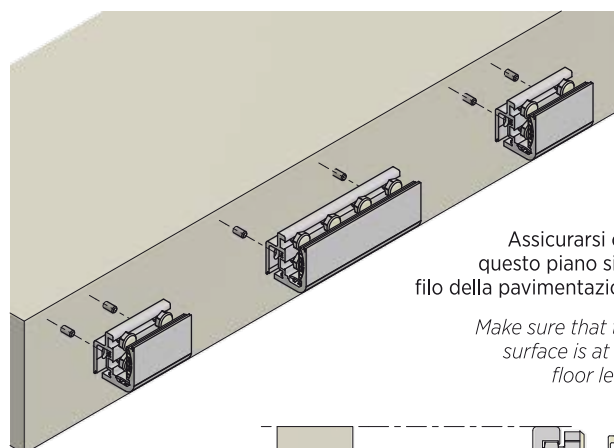

Assicurarsi che questo piano sia a filo della pavimentazione

Make sure that this surface is at the floor level

FISSAGGIO E REGOLAZIONE VETRO  
GLASS FIXING AND ADJUSTMENT

1.

Inserire tutti i piattelli inferiori ed uno superiore al centro del supporto centrale (1-2-3-4-6), quindi tenendo il vetro dritto con l'ausilio di una bolla mandare in battuta contro il vetro i piattelli 1-2-3. Serrare energicamente i piattelli 1 e 2, chiudere di mezzo giro il 3.

Insert all the lower plates and one upper plate in the middle of the central support (1-2-3-4-6), then, keeping the glass straight using a level, put the plates 1-2-3 in the right position against the glass. Fix plates 1 and 2, close the 3rd plate of half a turn.

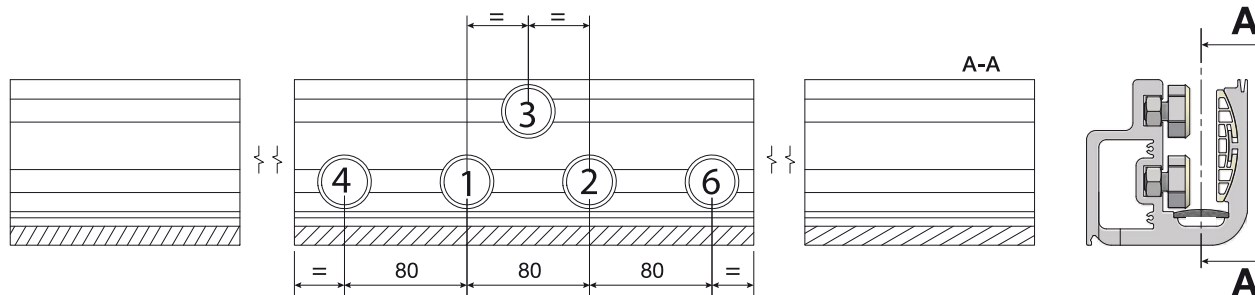

2.

Inserire i piattelli superiori mancanti (5-8-7) quindi serrare gli altri piattelli del supporto centrale secondo l'ordine riportato (4 con 5/6 con 7) quindi allineare il 3 al 2. Terminare serrando i piattelli mancanti (8 con 1).

Insert the missing upper plates (5-8-7), then fix the other plates of the central support according to the reported order (4 with 5/6 with 7), then align N. 3 to N. 2. Finish the operation fixing the plates (8 with 1).

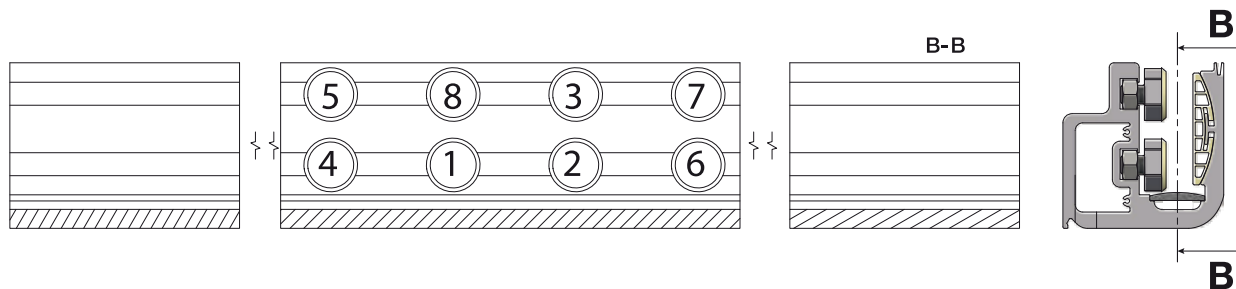

3.

Terminare inserendo e serrando i piattelli negli altri supporti secondo l'ordine riportato in figura 3 (9-10 / 11-12 / 13-14 / 15-16). N.B. Serrare sempre energicamente i piattelli inferiori, mentre i superiori è sufficiente che vengano serrati mezzo giro una volta portati a battuta.

Finish the operation inserting and fixing the plates in the other supports, according to the order reported in picture 3 (9-10 / 11-12 / 13-14 / 15-16). N.B. Always fix the lower plates, and fix the upper ones of half a turn when put in the right position

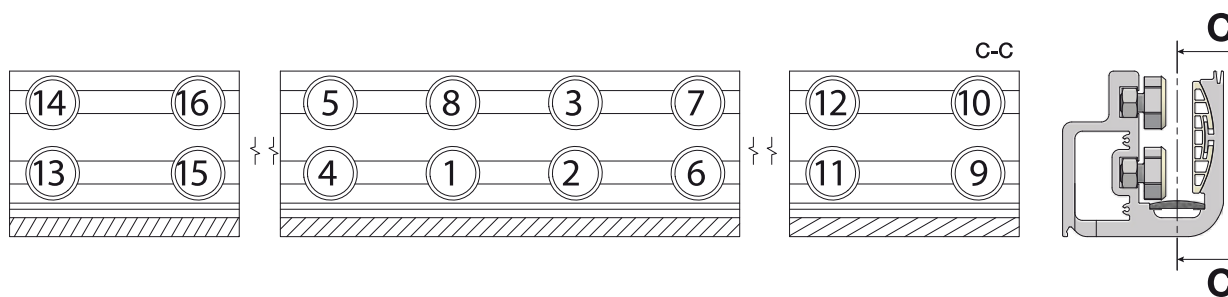

## SERIE TG 800R

**PROFILO IN BARRA PER FISSAGGIO FRONTE SOLETTA INDICATO PER EDILIZIA PUBBLICA**  
*BAR PROFILE CERTIFIED FOR FRONT WALL INSTALLATION IN PUBLIC SPACES*

Sistema a barra intera  
certificata per installazioni  
fronte soletta in ambienti  
pubblici, certificato  
3 kN/m

*Bar profile certified for front  
wall installation in public  
spaces, tested 3 kN/m*

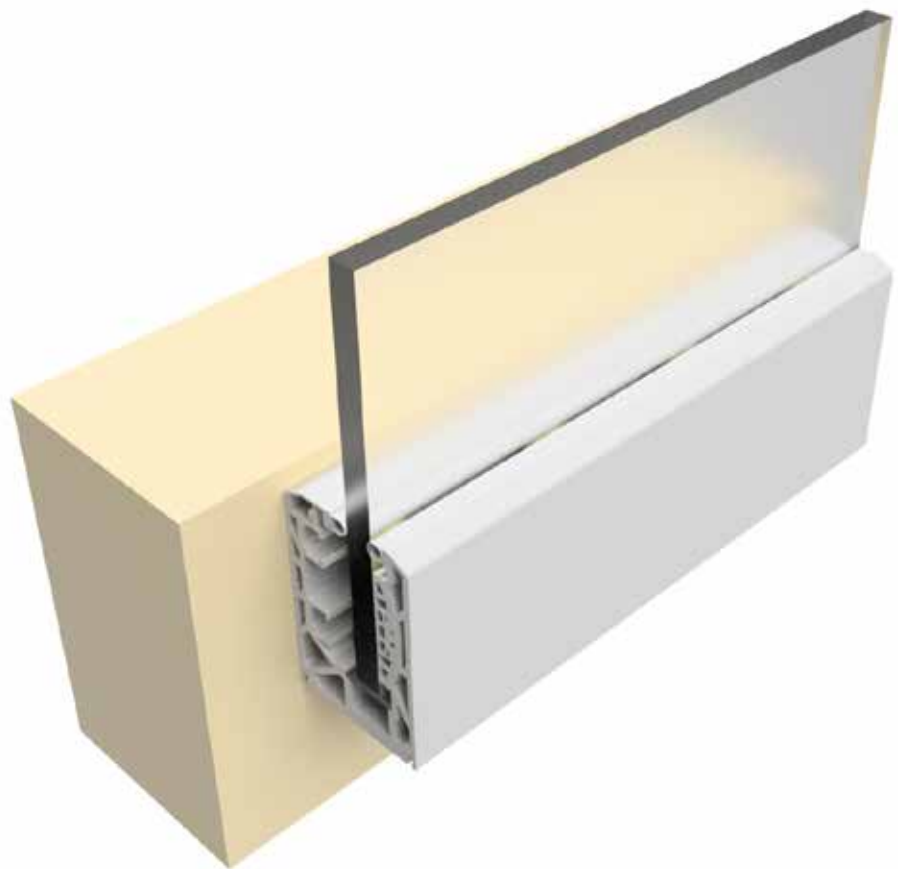
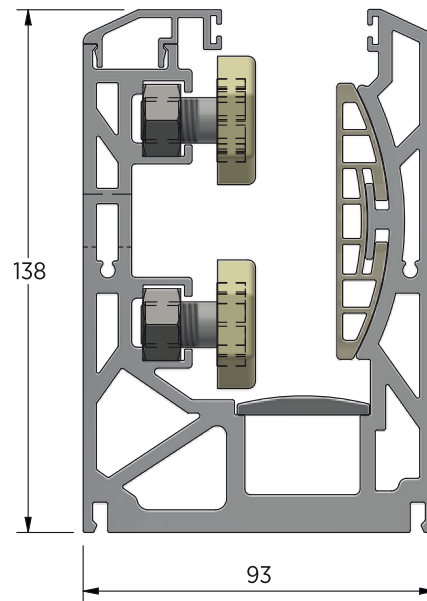

**RAPPORTO DI PROVA**  
*TEST REPORT*



## TG 802R

Supporto di fissaggio fronte soletta in barra intera da 3000mm.  
Per vetri stratificati da 21.52mm

*Front sole fixing support,  
3000mm bar lenght  
For stratified and  
tempered glass of  
21.52mm thickness*

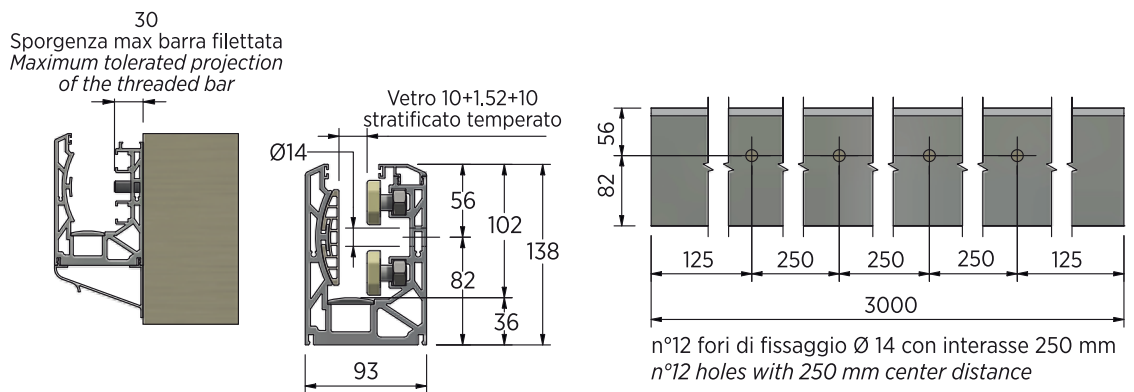

## TG 803R

Supporto di fissaggio fronte soletta in barra intera da 6000mm.  
Per vetri stratificati da 21.52mm

*Front sole fixing support,  
6000mm bar lenght  
For stratified and  
tempered glass of  
21.52mm thickness*

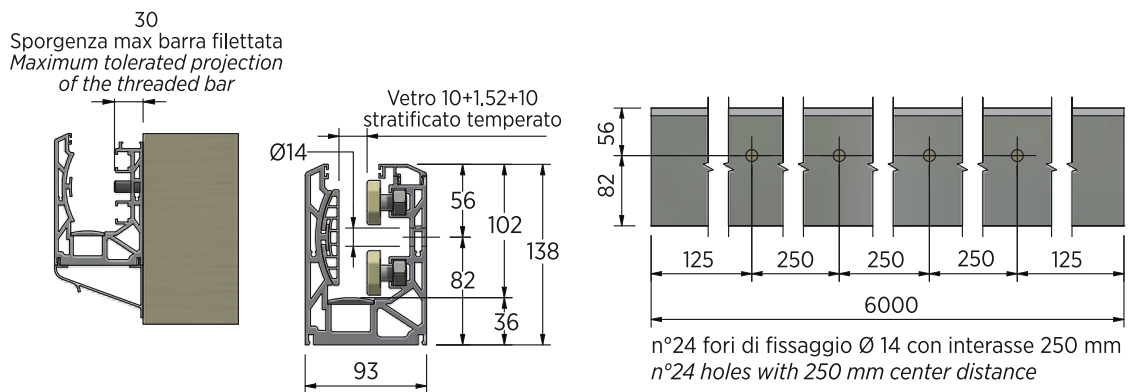

## TG 806R

Supporto di fissaggio fronte soletta in barra intera da 3000mm.  
Per vetri stratificati da 25.52mm

*Front sole fixing support,  
3000mm bar lenght  
For stratified and  
tempered glass of  
25.52mm thickness*

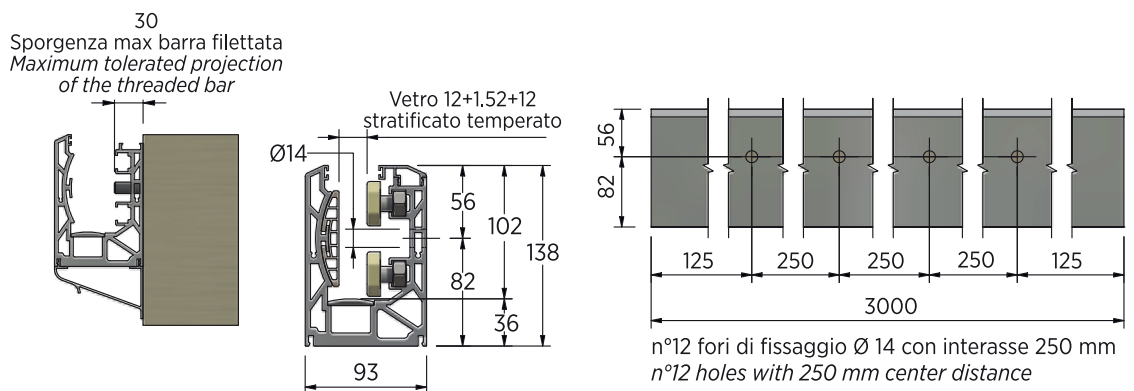

## TG 807R

Supporto di fissaggio fronte soletta in barra intera da 6000mm.  
Per vetri stratificati da 25.52mm

*Front sole fixing support,  
6000mm bar lenght  
For stratified and  
tempered glass of  
25.52mm thickness*

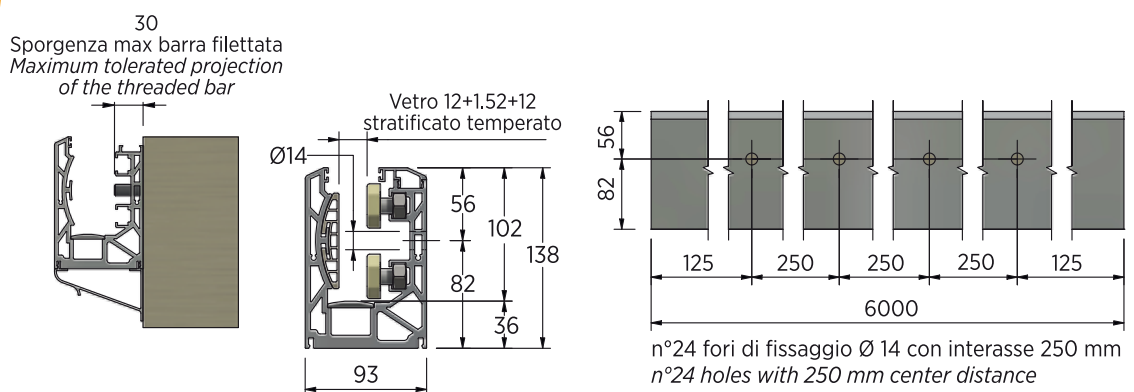

ACCESSORI E PROFILATI | ACCESSORIES AND PROFILES

**TG 816**

Copertella per supporti fronte soletta (L.3000 mm) per supporti TG 802, 803, 806, 807, 810, 811, 802R, 803R, 806R, 807R

*Front wall supports cover (L.3000 mm) for TG 802, 803, 806, 807, 810, 811, 802R, 803R, 806R, 807R*

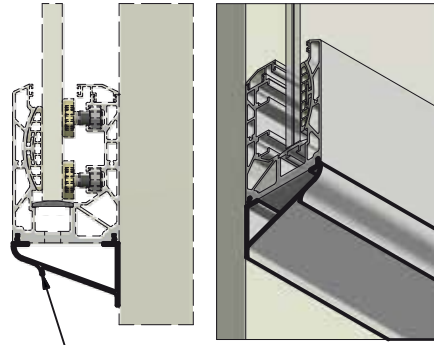

Dotato di rompigoccia  
*With drip profile*

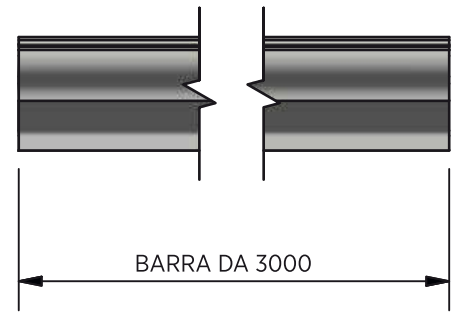

**TG 817**

Copertella per supporti fronte soletta (L.6000 mm) per supporti TG 802, 803, 806, 807, 810, 811, 802R, 803R, 806R, 807R

*Front wall supports cover (L.6000 mm) for TG 802, 803, 806, 807, 810, 811, 802R, 803R, 806R, 807R*

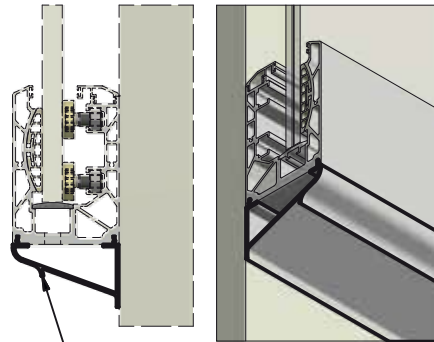

Dotato di rompigoccia  
*With drip profile*

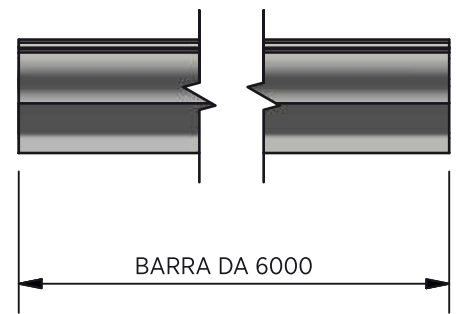

Trasporto a cura del cliente  
*Transport by the customer*

**TG 818**

Tappo per supporti fronte soletta

*Front side support plug*

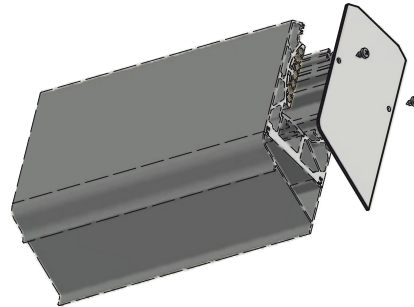

**TG 820**

Tappo fronte soletta, uso scale

*Side plug for stairs use only*

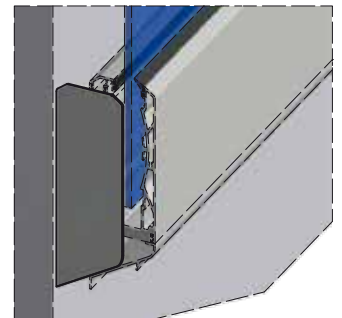

**TG 819**

Fissaggio Puntuale Regolabile  
*Adjustable Point Fixing*

Interamente in alluminio anodizzabile o verniciabile

*Entirely in aluminum anodizable or paintable*

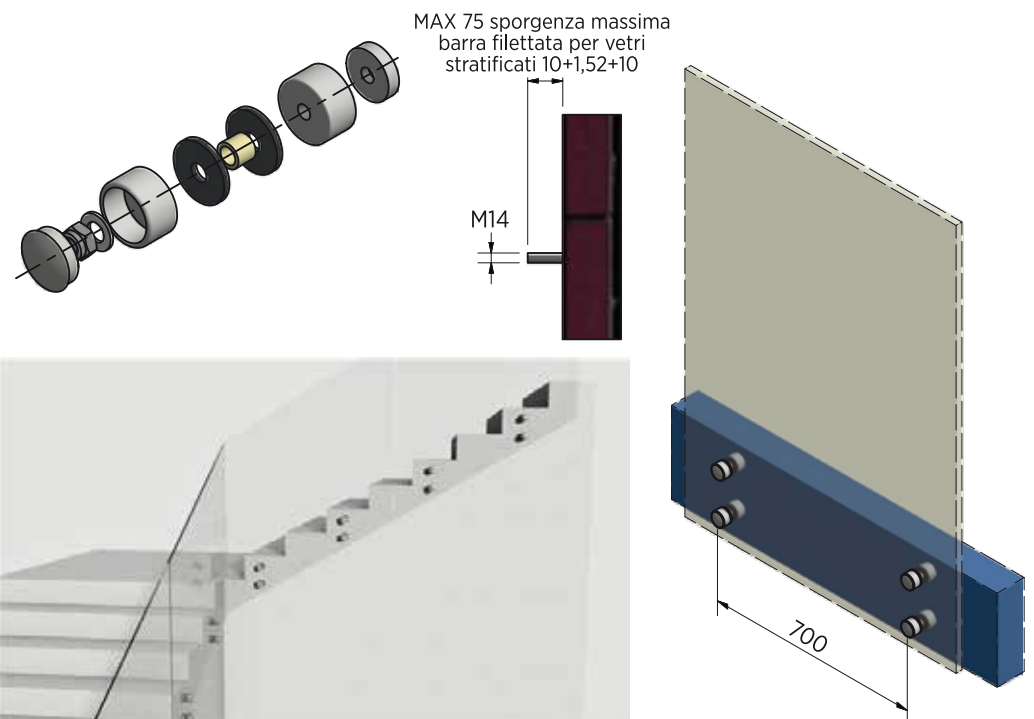

ISTRUZIONI DI MONTAGGIO TG 800 | ASSEMBLY INSTRUCTION

**1.** Posare la barra e usare gli appositi fori per ancorarla frontalmente alla soletta (per gli interessi di fissaggio vedi pag. supporti). L'unica accortezza richiesta in questa operazione è di non far sporgere la barra filettata più di 30 mm dalla soletta, altrimenti si verificheranno interferenze con i profili che andranno successivamente inseriti nei supporti. Agganciare infine il carter inferiore ed eventualmente fissarlo alla muratura con viteria (in tal caso occorrerà forare il profilo).

*Lay the bar and use the appropriate holes to anchor it to the front sole (for fixing distances see the article page). The only precaution required in this operation is to project the threaded bar not more than 30 mm from the front sole level, otherwise there will be interference with the profiles which will subsequently be inserted into the supports. Finally, hook the lower casing and fix it to the masonry with screws (in this case it will be necessary to drill the profile)*

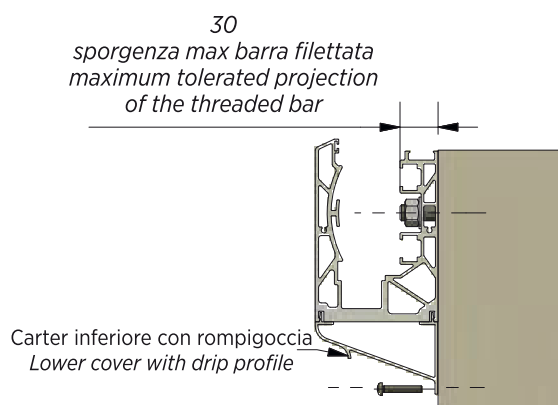

**2.** Inserire nella barra il profilo mezzeluna basculante e il profilo d'appoggio del vetro in pvc grigio.

*Insert the tilting half-moon profile and the gray PVC glass supports profile into the bar.*

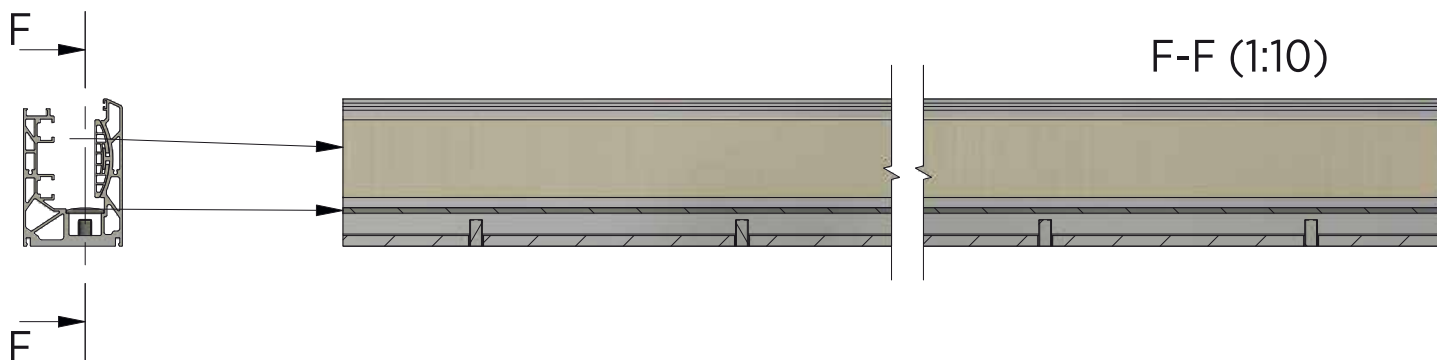

**3.** Inserire la guarnizione TG 309 nell'apposita sede presente nel supporto, inserire i vetri e i piattelli nelle guide. Impartire ai vetri l'inclinazione desiderata, quindi mandare in battuta i piattelli contro il vetro. Serrare alternativamente i piattelli inferiori e superiori, i piattelli inferiori andranno serrati energicamente mentre quelli superiori sarà sufficiente serrarli mezzo giro dopo che gli stessi saranno stati messi in battuta con il vetro.

*Insert the TG 309 gasket in the appropriate seat in the support, insert the glass and the plates into the guides. Give the desired inclination to the glass, then knock the plates against the glass. Alternately tighten the lower and upper plates, the lower plates must be tightened vigorously while the upper ones will be sufficient to tighten them half a turn after they have been put in contact with the glass.*

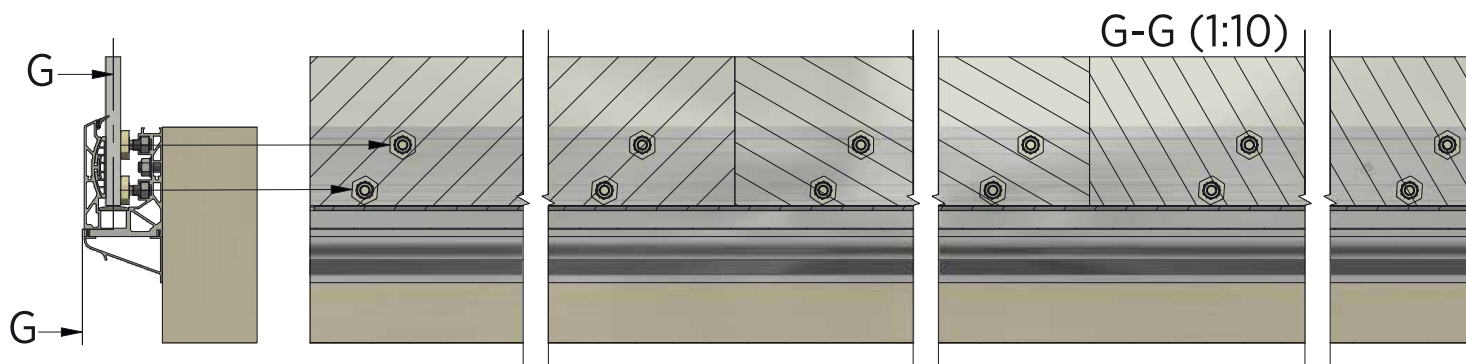

**4.** Inserire il profilo di copertura a scatto con guarnizione TG 309 montata, quindi chiudere lateralmente il sistema con i tappi.

*Insert the snap cover profile with the TG 309 gasket fitted, then close the system laterally with plug.*



## SERIE TG 1000

### SOLUZIONE A BARRA INTERA DA 3000 O 6000 mm

BAR PROFILE, 3000 OR 6000 mm LENGHT

Soluzione a barra intera rivisitata e più performante con certificazioni, accessori, profilati e istruzioni di montaggio

*Bar profile revisited and more performing with test reports, accessories and profiles assembly instruction*

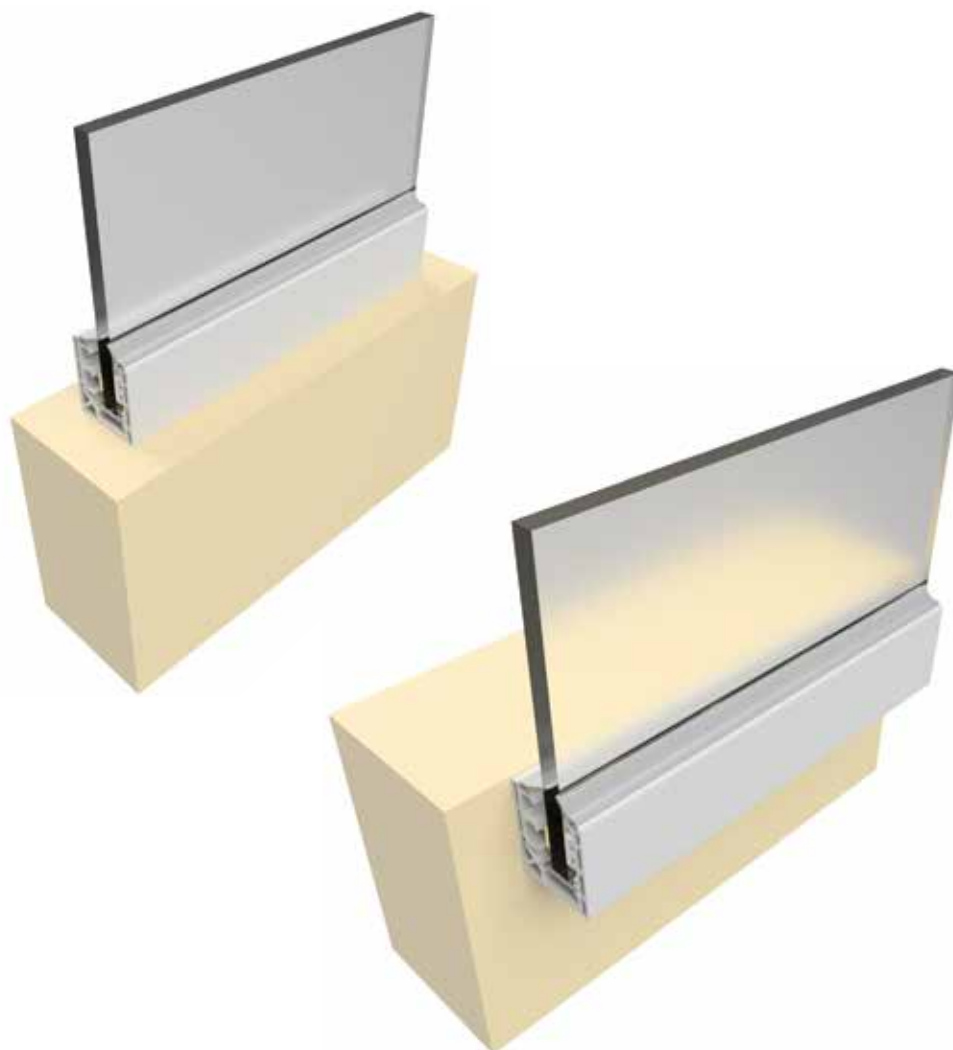
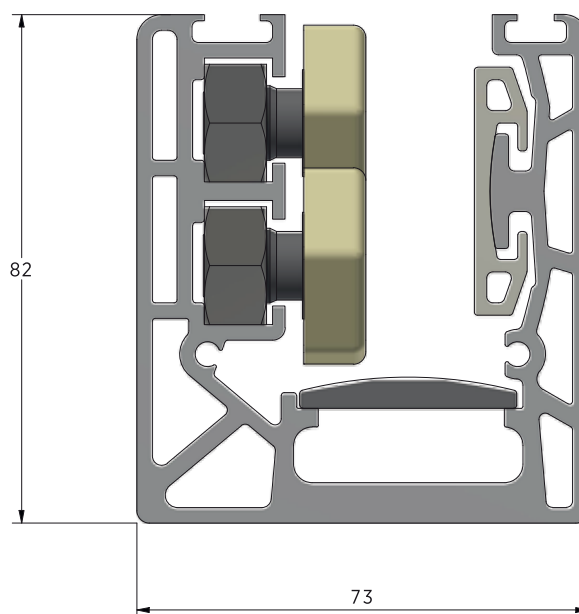

RAPPORTO DI PROVA  
TEST REPORT



### TG 1000

Supporto di fissaggio a pavimento in barra intera da 3000mm per vetri stratificati e temperati da 17,52 mm

*Floor fixing support, 3000 mm bar length. For stratified and tempered glass of 17,52 mm thickness.*

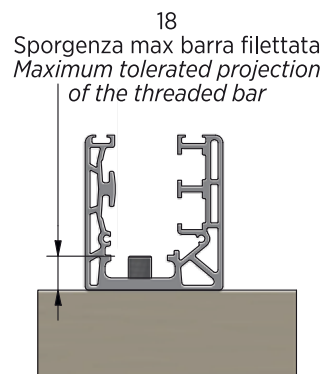
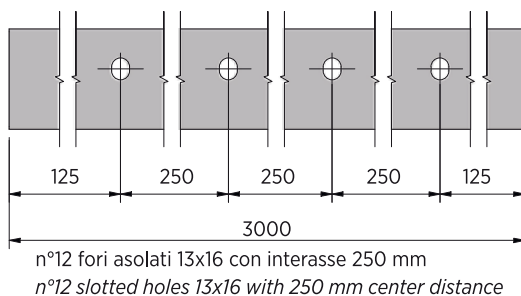

### TG 1001

Supporto di fissaggio a pavimento in barra intera da 6000mm per vetri stratificati e temperati da 17,52 mm

*Floor fixing support, 3000 mm bar length. For stratified and tempered glass of 17,52 mm thickness.*

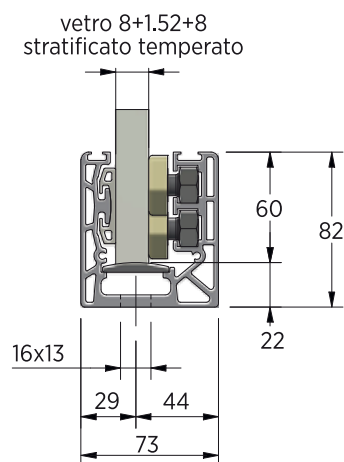
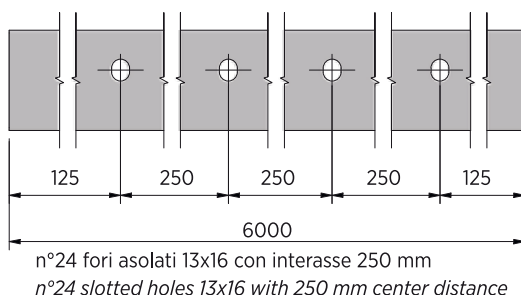

### TG 1002

Supporto per fronte muretti in barra da 3000 mm Per vetri stratificati e temperati da 17,52 mm

*Front wall support in full bar, 3000 mm length only for low height parapets For stratified and tempered glass, 17,52 mm thickness*

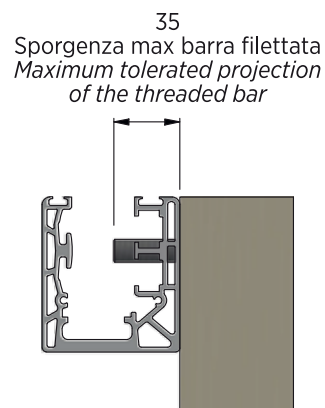
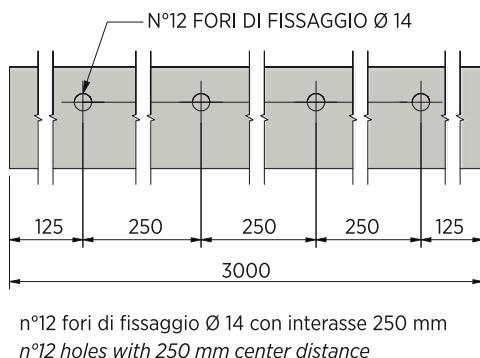

### TG 1003

Supporto per fronte muretti in barra da 6000 mm Per vetri stratificati e temperati da 17,52 mm

*Front wall support in full bar, 6000 mm length only for low height parapets For stratified and tempered glass, 17,52 mm thickness*

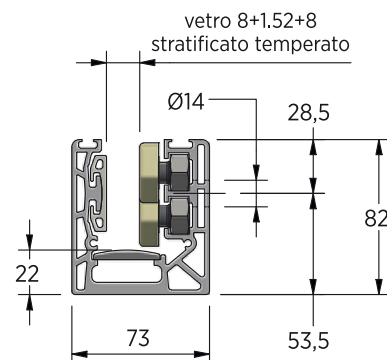
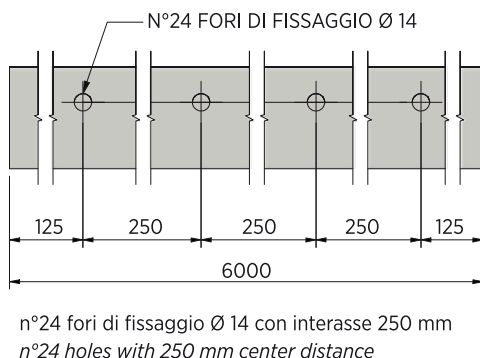

## TG 1004

Tappo per supporti a pavimento  
Floor support side plug

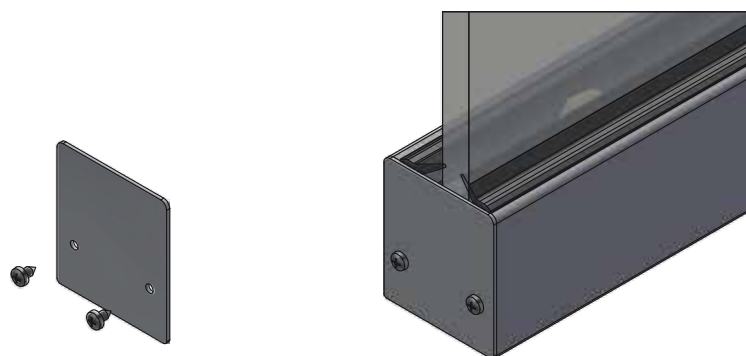

## TG 203

Profilo scarico acque per supporti a pavimento (L. 3000 mm)  
TG 1000 - 1001

Water exhaust profile for floor fixed supports (L. 3000 mm)  
TG 1000 - 1001

Le barre sono già forate e predisposte per il fissaggio

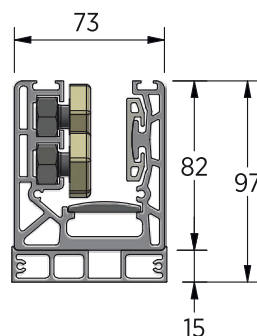

Profile bars are provided with fixing holes

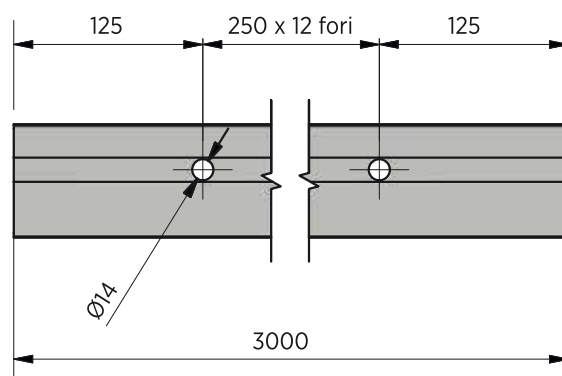

## TG 204

Profilo scarico acque per supporti a pavimento (L. 6000 mm)  
TG 1002 - 1003

Water exhaust profile for floor fixed supports (L. 6000 mm)  
TG 1002 - 1003

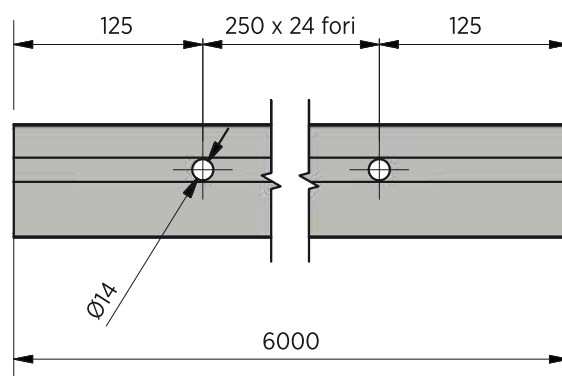

## TG 205

Tappo per profili scarico acque TG 203, TG 204

Water discharge profile plug, for TG 203, TG 204

Montare il tappo prima della posa del profilo scarico acque  
Fit the plug before laying the water drainage profile

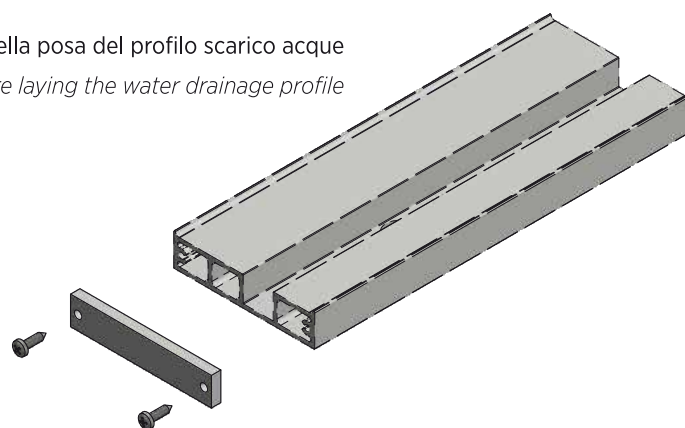



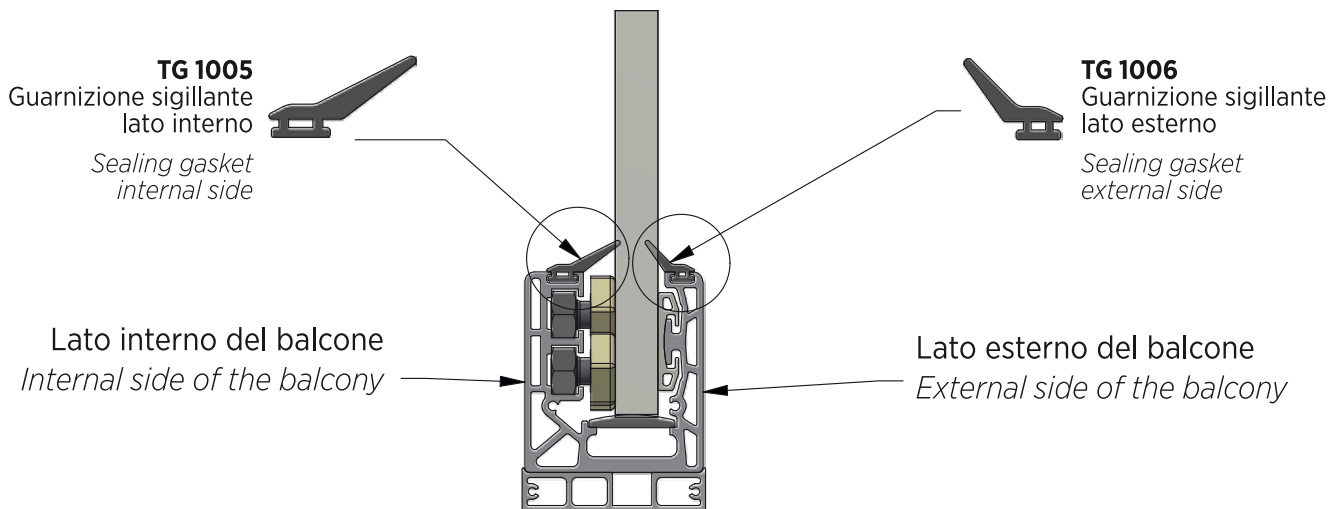

Entrambe le guarnizioni vengono fornite in metri, occorre considerare quindi un quantitativo di ciascuna pari al metraggio totale dei profili TG 1000 / 1001 / 1002 / 1003 ordinati, per esempio, ordinando n°1 TG 1000 occorreranno 3 metri di TG 1005 + 3 m di TG 1006

*Both gaskets are supplied in meters, therefore it is necessary to consider a quantity of each equal to the total footage of the TG 1000 / 1001 / 1002 / 1003 profiles ordered, for example, ordering x1 TG 1000 will require 3 meters of TG 1005 + 3 meters of TG 1006*



ISTRUZIONI DI MONTAGGIO | ASSEMBLY AND PROFILES

- 1.** Posare la barra e usare gli appositi fori per ancorarla alla pavimentazione (per gli interassi di fissaggio vedi pag. supporti). L'unica accortezza richiesta in questa operazione è di non far sporgere la barra filettata più di 18 mm da filo pavimentazione, altrimenti si verificherebbero interferenze con i profili che andranno successivamente inseriti nei supporti

*Lay the bar and use the appropriate holes to anchor it to the floor (for fixing distancesses see the article page). The only precaution required in this operation is to project the threaded bar not more than 18 mm from the floor leve, otherwise there will be interference with the profiles wich will subsequently be into the supports*

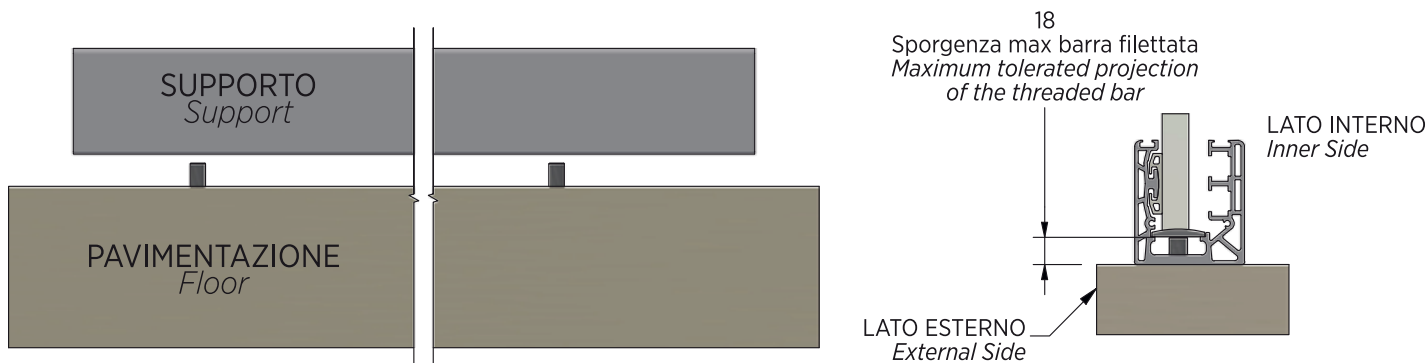

- 2.** Inserire nella barra il profilo mezzaluna basculante e il profilo d'appoggio del vetro in pvc grigio

*Insert the tilting half-moon profile and the grey PVC glass support profile into the bar*

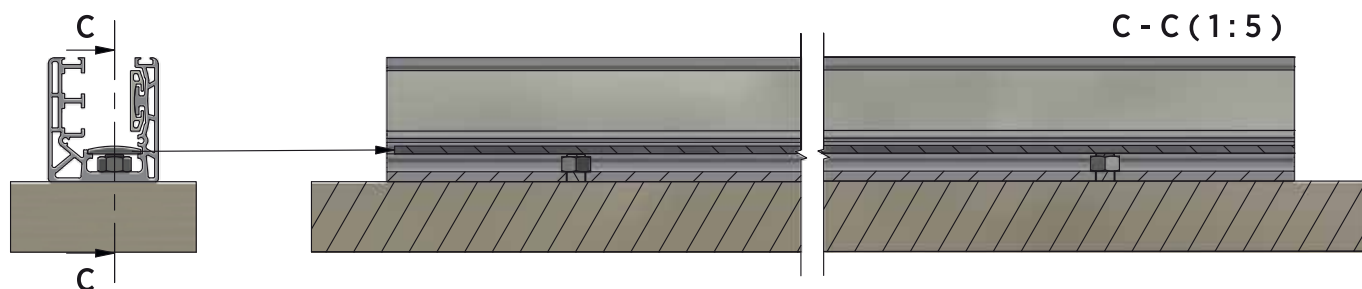

- 4.** Inserire la guarnizione TG 1006 nell'apposita sede presente sul supporto, inserire i vetri e i piattelli nelle guide. Impartire ai vetri l'inclinazione desiderata, quindi mandare in battuta i piattelli contro il vetro. Serrare alternativamente i piattelli inferiori e superiori, i piattelli inferiori andranno serrati energicamente mentre quelli superiori sarà sufficiente serrarli mezzo giro dopo che gli stessi saranno stati messi in battuta contro il vetro

*Insert the TG 1006 gasket in the appropriate seat in the support, insert the glass and the plates into the guides. Give the desired inclination to the glass, then knock the plates against the glass. Alternately tighten the lower and upper plates, the lower plates must be tightened vigorously while the upper ones will be sufficient to tighten them half a turn after they have been put in contact with the glass*

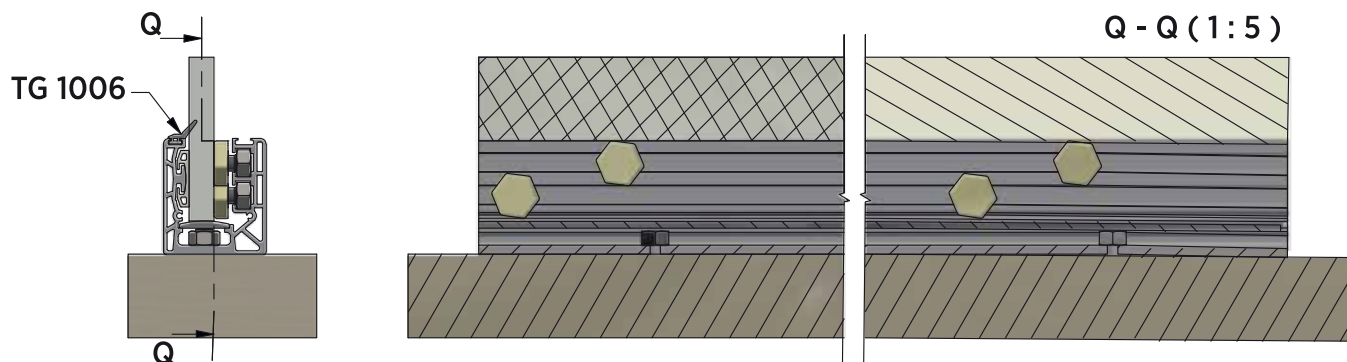

- 4.** Inserire la guarnizione a pressione interna TG 1005, infine chiudere lateralmente il sistema con i tappi TG 1004

*Insert the TG 1005 gasket in its seat, then close the system laterally with the TG 1004 plugs*



ISTRUZIONI DI MONTAGGIO | ASSEMBLY AND PROFILES

- 1.** Distribuire equamente lungo tutta la barra di profilo i piattelli fermavetro con relative viti e copritesta in nylon, inserire anche il profilo poggiavetro in pvc grigio e il profilo laterale d'appoggio in policarbonato trasparente

*Evenly distribute the glass retaining plates along with the nylon screws and head covers along the whole profile bar, also insert the gray PVC glass support profile and the transparent polycarbonate lateral support profile*

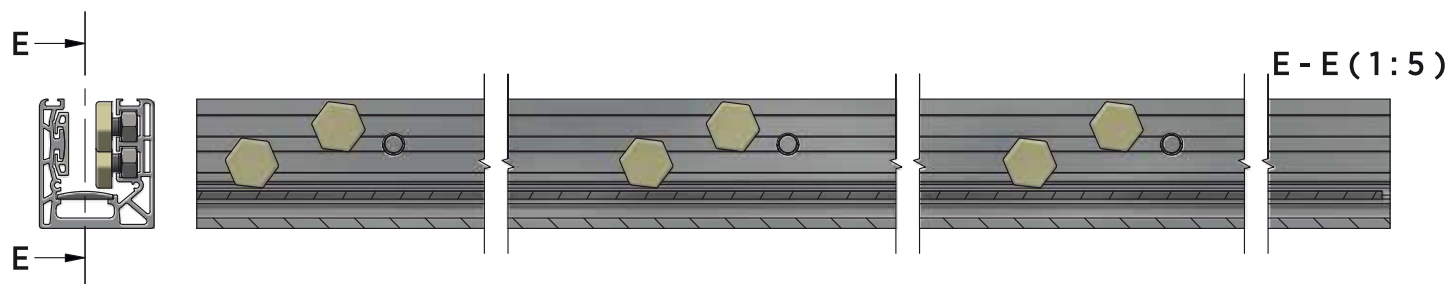

- 2.** Il profilo può ora essere ancorato alla muratura sfruttando gli appositi fori di fissaggio, le barre filettate, per non interferire con il vetro, non dovranno sporgere più di 35 mm. Effettuato il bloccaggio, inserire la guarnizione a pressione esterna TG 1006

*The profile can now be anchored to the wall by using the appropriate fixing holes, the threaded bars, in order not to interfere with the glass, must not protrude more than 35 mm. After locking, insert the TG 1006 external pressure gasket*

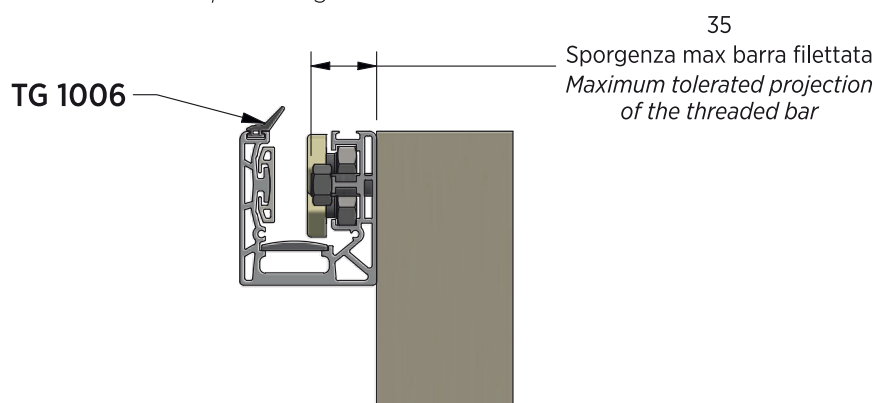

- 3.** Inserire il vetro e bloccarlo serrando i piattelli esagonali in nylon con l'apposita chiave TG 409. Serrare energicamente i piattelli inferiori, portare i piattelli superiori in battuta contro il vetro e dare un ulteriore giro, ripetere quindi l'operazione per ciascun vetro. È importante non eccedere nel serraggio dei piattelli superiori, i quali fungono principalmente come piano di riscontro per il vetro. Infine inserire la guarnizione a pressione per il lato interno (art. TG 1005) e i tappi di chiusura laterali TG 1004.

*Insert the glass and lock it by tightening the hexagonal nylon plates with the special wrench TG 409. Firmly tighten the lower plates, bring the upper plates against the glass and give another turn, then repeat the operation for each glass. It is important not to exceed to tightening the upper plates, which mainly act as a surface feedback plan for the glass. Finally insert the pressure seal for the internal side (art. TG 1005) and the side plugs TG 1004.*

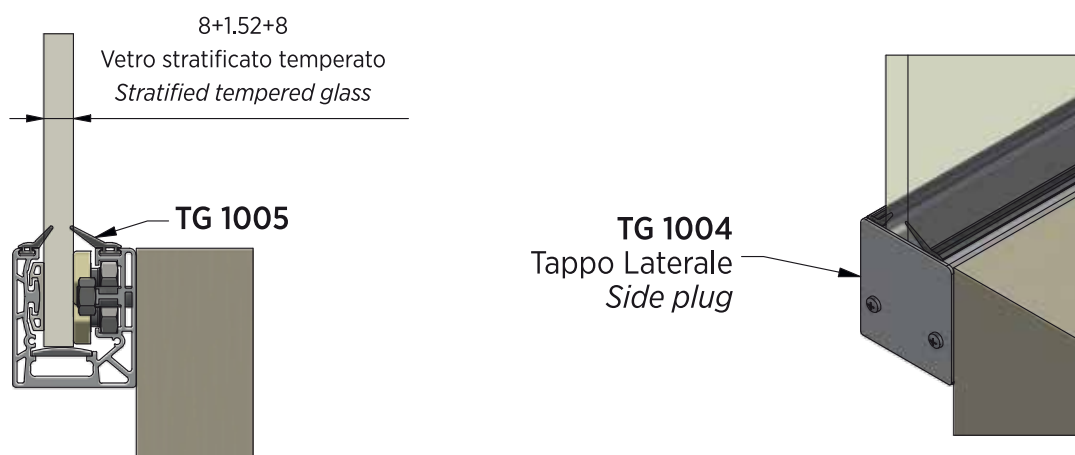





### TGS 000

Guarnizione a scomparsa per sistemi TG e TGS

- fornito in rotoli
- colore grigio

*Concealed gasket for TG and TGS system*

- supplied in rolls
- available in gray color

TGS 100-200-300-400 (10+1.52+10) – 600 (10+1.52+10)

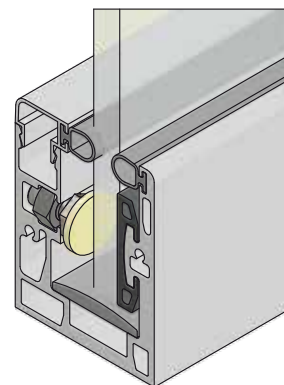
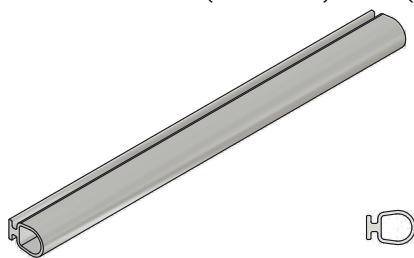

Non utilizzabile TGS 400 e TGS 600 con vetro 8+1.52+8  
*Not suitable for TGS 400 and TGS 600 with 8+1.52+8 glass*

La guarnizione previene l'infiltrazione di acqua e polvere nel sistema  
*The gasket prevents water and dust infiltration into the system*

### TG 309

Guarnizione per copertella laterale

- fornito in rotoli
- disponibile nero e trasparente

*Gasket for side cover*

- supplied in rolls
- available in black and transparent colors

TG 200-300-400-500-600-800-900

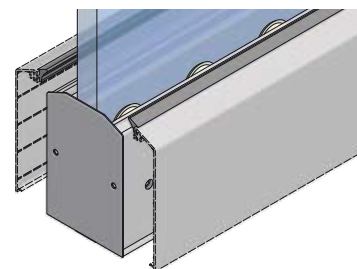

La guarnizione previene l'infiltrazione di acqua e polvere nel sistema  
*The gasket prevents water and dust infiltration into the system*

Disponibile in colore nero, grigio e trasparente (solo per uso in interni)  
*Available in black, gray and transparent (only for indoor use) colors*

### GU 100

Guarnizione trasparente per separazione vetri

- di spessore 8+1.52+8 mm
- fornito in rotoli
- colore trasparente omogeneo alla vetratura

*Transparent seal to separate glasses*

- 8+1.52+8 mm thick
- deliver in rolls
- transparent colour, homogeneous to glass

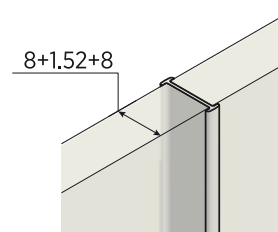
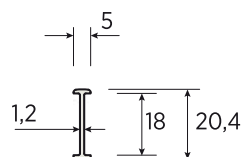

La guarnizione evita che i vetri vengano a contatto tra loro  
*The seal prevent the glasses from being in contact the one with the other*

### GU 101

Guarnizione trasparente per separazione vetri

- di spessore 10+1.52+10 mm
- fornito in rotoli
- colore trasparente omogeneo alla vetratura

*Transparent seal to separate glasses*

- 10+1.52+10 mm thick
- deliver in rolls
- transparent colour, homogeneous to glass

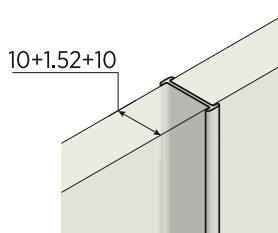
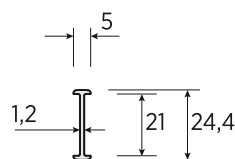

La guarnizione evita che i vetri vengano a contatto tra loro  
*The seal prevent the glasses from being in contact the one with the other*

### TG 103

Guarnizione trasparente per separazione vetri

- di spessore 12+1.52+12 mm
- fornito in rotoli
- colore trasparente omogeneo alla vetratura

*Transparent seal to separate glasses*

- 12+1.52+12 mm thick
- deliver in rolls
- transparent colour, homogeneous to glass

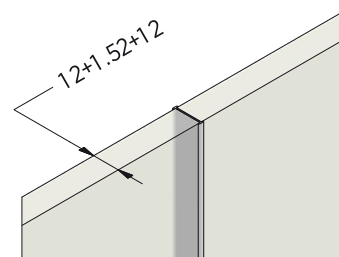
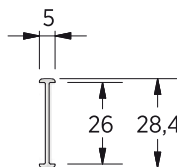
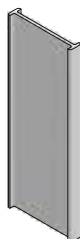

La guarnizione evita che i vetri vengano a contatto tra loro

*The seal prevent the glasses from being in contact the one with the other*

### TG 316

Guarnizione per vetro

- 8+0.76+8 mm
- 8+1.52+8 mm

*Gasket for glass*

- 8+0.76+8 mm
- 8+1.52+8 mm

Per corrimani TG 314 - TG 315

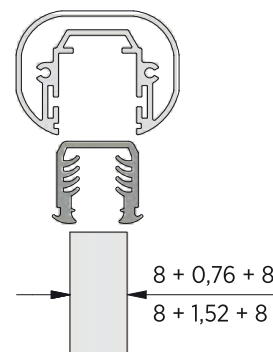
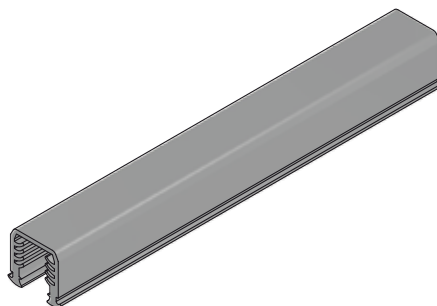

### TG 322

Guarnizione per vetro

- 10+0.76+10 mm
- 10+1.52+10 mm

*Gasket for glass*

- 10+0.76+10 mm
- 10+1.52+10 mm

Per corrimani TG 314 - TG 315

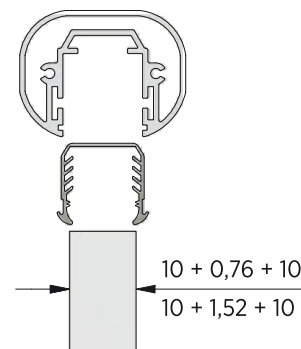
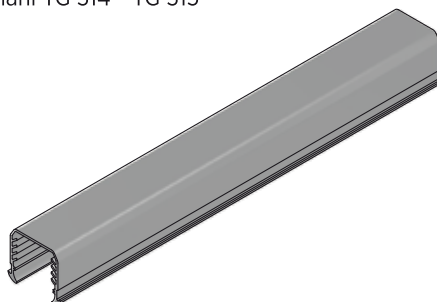

### TG 335

Guarnizione per vetro

- 8+0.76+8 mm
- 8+1.52+8 mm

*Gasket for glass*

- 8+0.76+8 mm
- 8+1.52+8 mm

Per corrimani TG 314 - TG 315

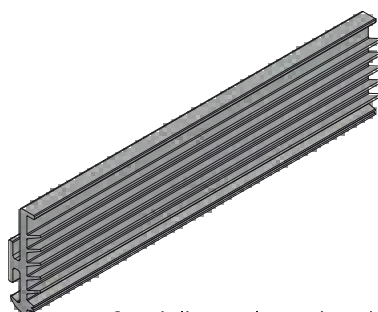

Consigliata nel caso in cui venga inserita la luce a led nel corrimano.

*Recommended if led strips are inserted in the handrail.*

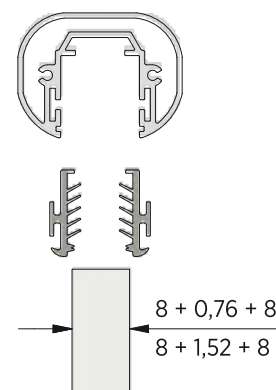

### TG 336

Guarnizione per vetro

- 10+0.76+10 mm
- 10+1.52+10 mm

Gasket for glass

- 10+0.76+10 mm
- 10+1.52+10 mm

Per corrimani TG 314 - TG 315

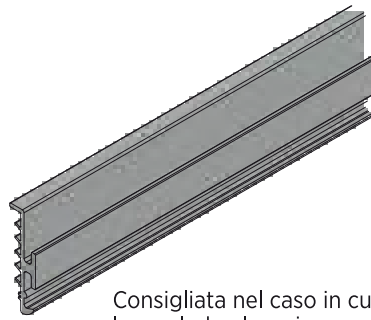

Consigliata nel caso in cui venga inserita la luce a led nel corrimano.

Recommended if led strips are inserted in the handrail.

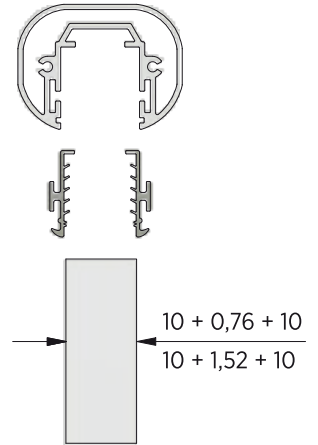

### TG 314

Corrimano per vetro

- barra da 6,5 m
- trasporto a cura del cliente

Handrail for glass

- 6,5 m bar
- transportation at the customer's expense

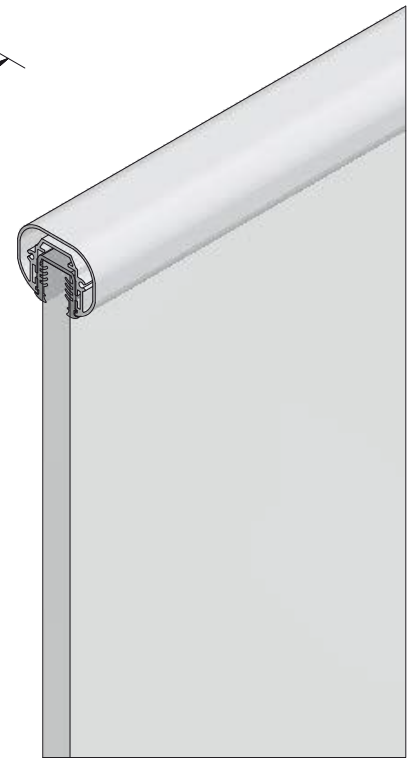
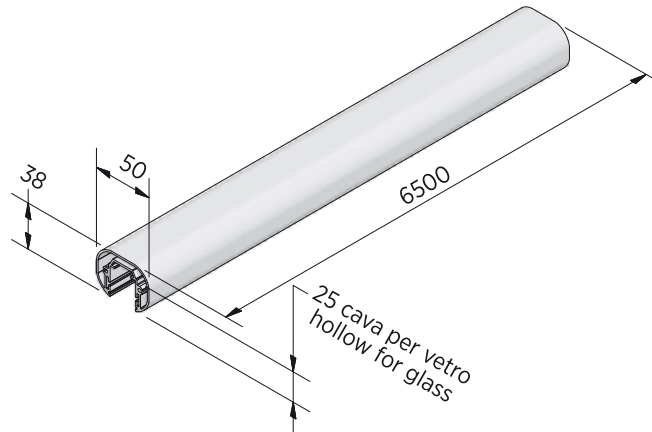

### TG 315

Corrimano per vetro

- barra da 3,25 m

Handrail for glass

- 3,25 m bar

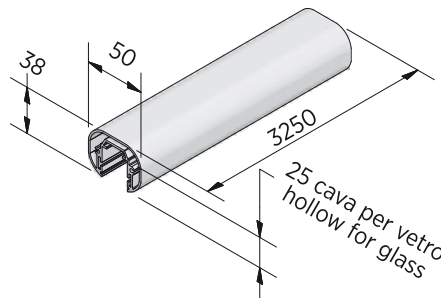

### TG 321

Tappo per corrimano  
TG 314- TG 315

Handrail plug  
TG 314 - TG 315

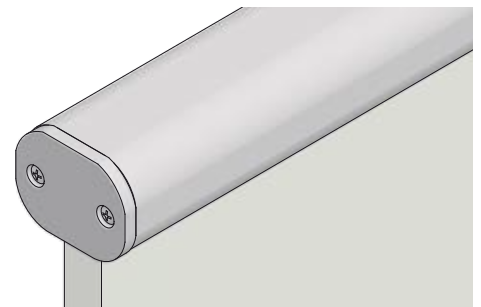
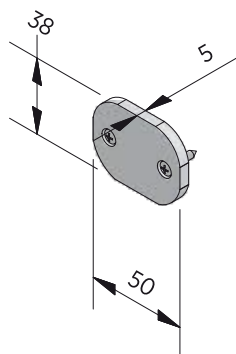



### TGS 004

Pinza per fissaggio del vetro alla muratura  
Per vetri stratificati temperati 8+1.52+8

*Pliers for fixing the glass to the masonry  
For tempered laminated glass 8 + 1.52 + 8*

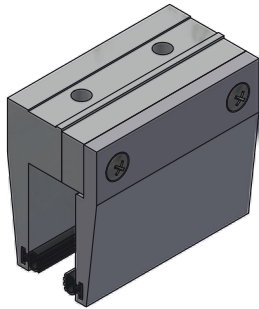

Per vetri  
8+1.52+8  
10+1.52+10  
12+1.52+12  
For glasses  
8+1.52+8  
10+1.52+10  
12+1.52+12

### TGS 005

Pinza per fissaggio del vetro alla muratura  
Per vetri stratificati temperati 10+1.52+10

*Pliers for fixing the glass to the masonry  
For tempered laminated glass 10+1.52+10*

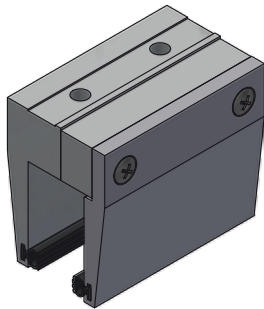

### TGS 006

Pinza per fissaggio del vetro alla muratura  
Per vetri stratificati temperati 12+1.52+12

*Pliers for fixing the glass to the masonry  
For tempered laminated glass 12+1.52+12*

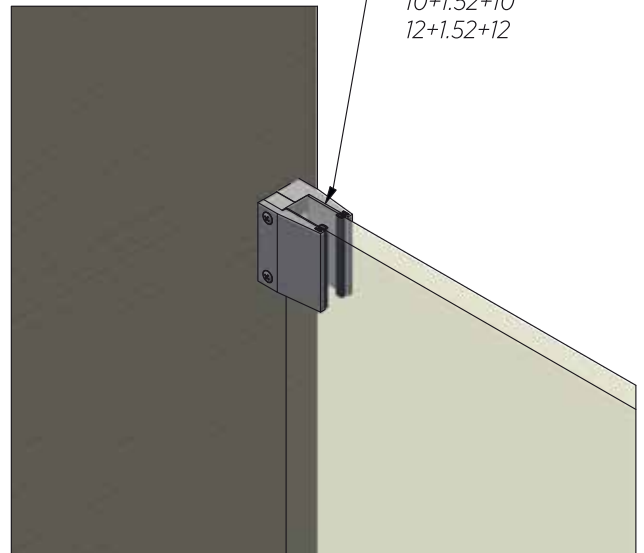
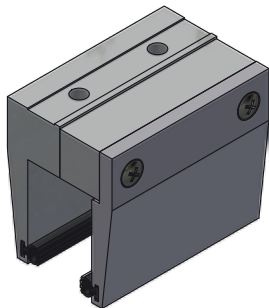

### TGS 007

Pinza per allineamento vetri.  
Per vetri stratificati temperati di spessore 8+1.52+8 e 10+1.52+10

*Glass alignment pliers.  
For tempered laminated glass of thickness 8+1.52+8 and 10+1.52+10*

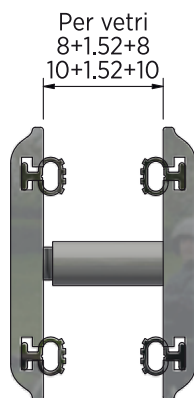

### TGS 008

Pinza per allineamento vetri.  
Per vetri stratificati temperati di spessore 12+1.52+12

*Glass alignment pliers.  
For tempered laminated glass of thickness 12+1.52+12*

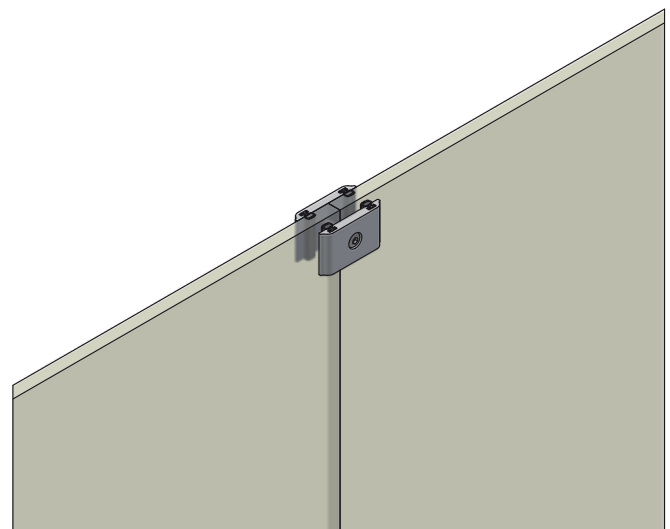
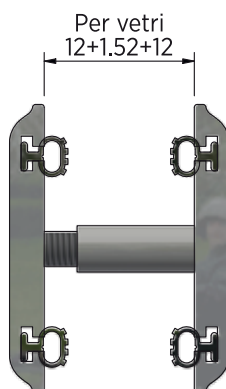

### TG 409

Chiave ergonomica particolarmente adatta a stringere i piattelli esagonali  
 Compatibile con tutti i supporti ad eccezione delle serie TG 300 e TG 600

*Ergonomic key, particularly suitable to tighten hexagonal plates.  
 Compatible with all supports except TG 300 and TG 600 series.*

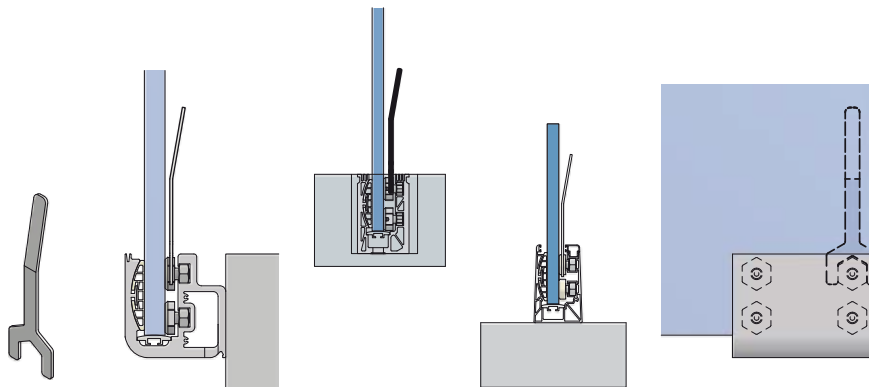

### TG 339

Corrimano per vetro  
 • 8+1.52+8 mm barra da 3,25 m

*Handrail for*  
 • 8+1.52+8 mm glass  
 3,25 m bar

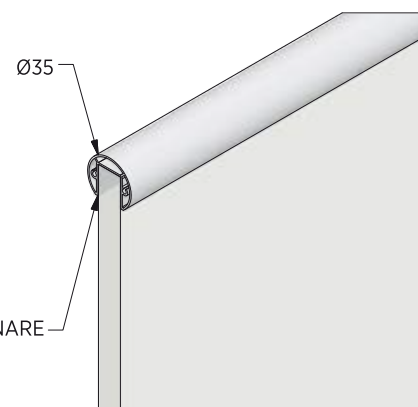
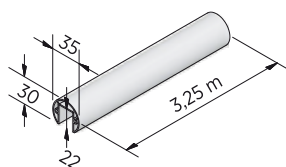

### TG 340

Corrimano per vetro  
 • 8+1.52+8 mm barra da 6,5 m

*Handrail for*  
 • 8+1.52+8 mm glass  
 6,5 m bar

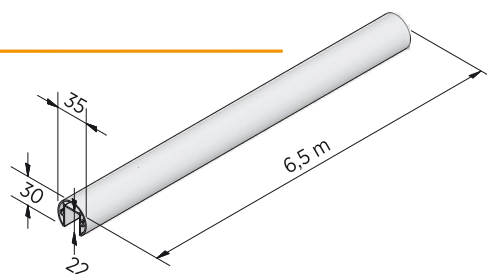

SILICONARE

### TG 343

Tappo per corrimano  
 TG 339 - 340

*Caps for TG 339 - 340 handrail*

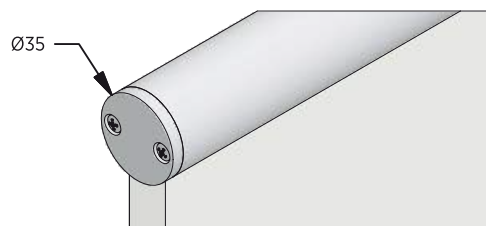
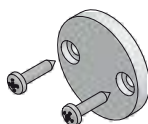

### TG 341

Corrimano per vetro  
 • 10+1.52+10 mm barra da 3,25 m

*Handrail for*  
 • 10+1.52+10 mm glass  
 3,25 m bar

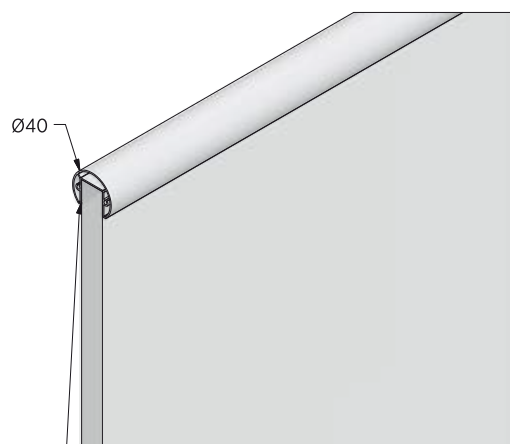
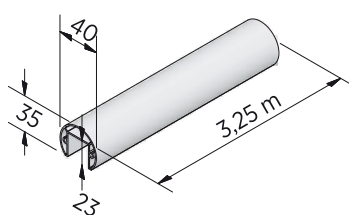

### TG 342

Corrimano per vetro  
 • 10+1.52+10 mm barra da 6,5 m

*Handrail for*  
 • 10+1.52+10 mm glass  
 6,5 m bar

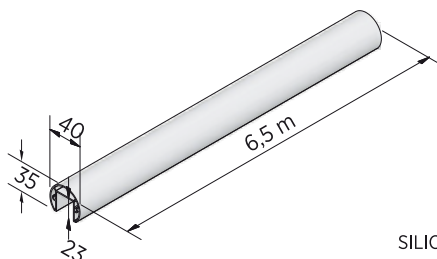

SILICONARE

### TG 344

Tappo per corrimano  
 TG 341 - TG 342

*Caps for TG 341 - Tga 342  
 handrail*

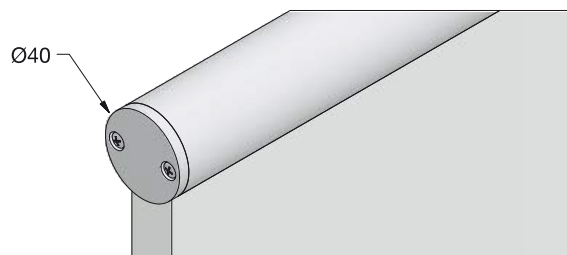
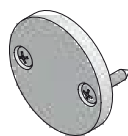

### TG 304

Kit led completo

- Alimentazione: 24V c.c
- Consumo: 14,4 W/m ca.
- Dimensioni: 10 x 2 mm
- 60 LED/m - tipo SMD 5050
- Bobine: da 5 mt
- Disponibile con luce bianca e multicolore

Complete LED kit

- Power supply: 24Vdc
- Consumption: approx. 14.4 W/m
- Dimensions: 10 x 2 mm
- 60 LED/m - type SMD 5050
- Coils: 5 m
- Available with white and multi-colour light



Il kit include tutta la cassetteria e il materiale necessario per ristabilire i collegamenti qualora la striscia LED venga tagliata in più parti

*The kit includes all of the wiring and the material required to re-establish the connections should the LED strip be cut into several sections*

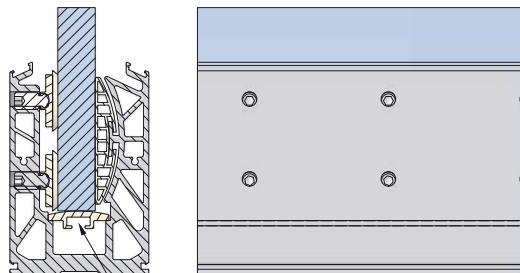

Applicare la striscia LED sull'apposito dissipatore TG 329 - TG 330 inserendo poi il tutto nella canalina in policarbonato

*Apply LED strips over the TG 329-TG330 heatsink, then insert all in the appropriate polycarbonate channel*

### TG 307

Telecomando per controllo led  
*Remote control for led*

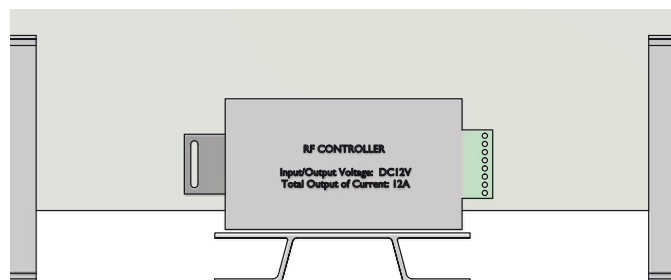

Il telecomando è un accessorio opzionale che consente di accendere/spengere il sistema LED, regolare il programma e la velocità di cambiamento del colore qualora vengano montate strisce multicolore

*The remote control is an optional accessory which can be used to switch the LED system on/off, to adjust the colour changing program and speed if multicolour strips are installed*

### TG 318

Ripetitore di segnale.

- per utilizzare telecomando e controller nelle installazioni più lunghe (ogni 10 mt. è necessario un ripetitore)

*Signal repeater*

- to use remote controller in longer installations (a repeater is necessary every 10 meter)

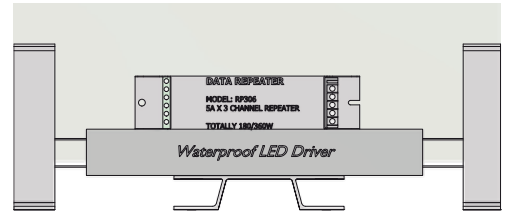

Montaggio interno al sistema  
*Installation within the system*

### TG 305

Alimentatore per strisce led

- grado di protezione: IP67
- potenza in uscita: 36W
- dimensioni di ingombro: 200x30x20 mm

*Power supply for LED strips*

- grade of protection: IP67
- output power: 36W
- Dimensions: 200x30x20 mm

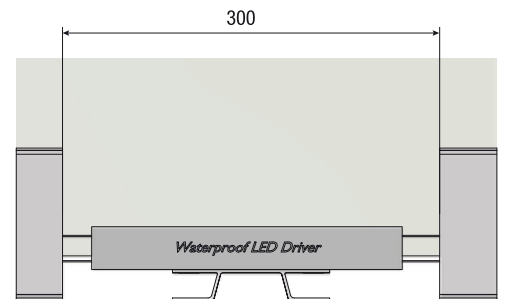

Montaggio interno al sistema  
*Installation within the system*

### TG 306

Alimentatore per strisce led

- grado di protezione: IP67
- potenza in uscita: 120W
- dimensioni di ingombro: 210x70x40 mm

*Power supply for LED strips*

- grade of protection: IP67
- output power: 120W
- Dimensions: 210x70x40 mm

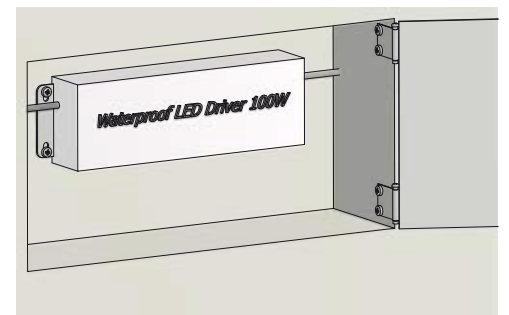
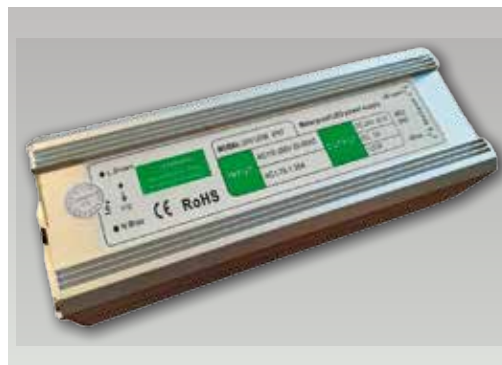

Montaggio interno al sistema  
*Installation within the system*

### TG 317

Alimentatore per strisce led

- grado di protezione: IP67
- potenza in uscita: 200W
- dimensioni di ingombro: 237x135x65 mm

*Power supply for LED strips*

- grade of protection: IP67
- output power: 200W
- Dimensions: 237x135x65 mm

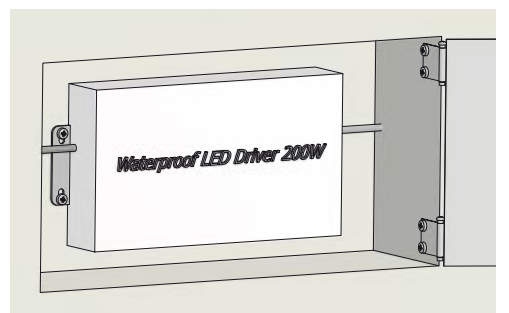
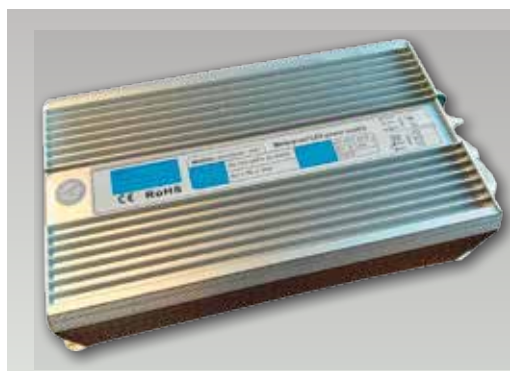

Montaggio interno al sistema  
*Installation within the system*

## LED E ACCESSORI | LED AND ACCESSORIES

### TG 311

Piastrina per striscia led  
*Plate for led strip*

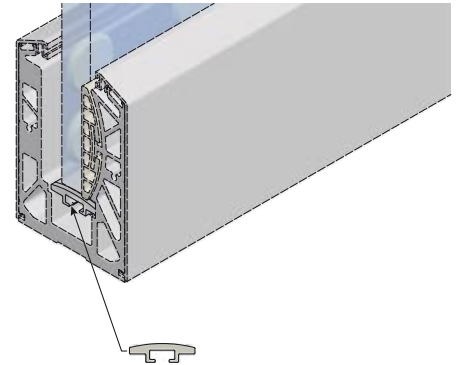
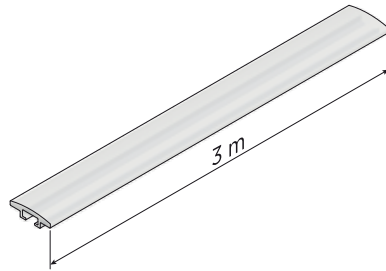

### TG 313

Piastrina per striscia led  

- trasporto a cura del cliente

*Plate for led strip*  

- transportation at the customer's expense

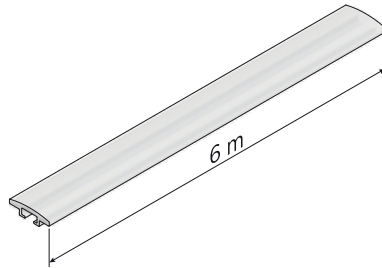

### TG 329

Dissipatore in alluminio  
per strisce led  
*Heatsink for led strips*

Barra da 3 m  
*3 m bar lenght*

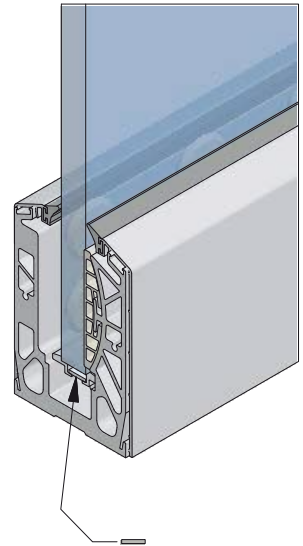
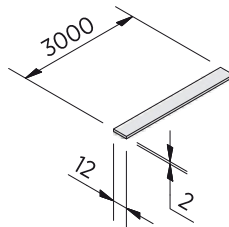

### TG 330

Dissipatore in alluminio  
per strisce led  
*Heatsink for led strips*

Barra da 6 m, trasporto  
a cura del cliente  
*6 m bar lenght, trasportation  
at the customers expense*

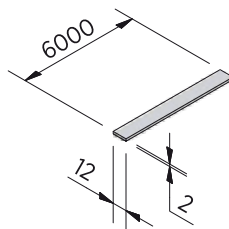



**TGS 50 - SISTEMA PER MURETTI**

	3 METRI	6 METRI
<i>PROFILO SOPRAMURETTO</i>	TGS 50	TGS 51
<i>TAPPO TGS 52</i>	TAPPO PER PROFILI TGS 50 - 51	

**TGS 100 - SISTEMA PER PARAPETTI**

	3 METRI	6 METRI
<i>PROFILO A PAVIMENTO</i>	TGS 100	TGS 101
<i>PROFILO FRONTE SOLETTA</i>	TGS 102	TGS 103
<i>TAPPO TGS 104</i>	TAPPO PER PROFILI TGS 100 - 101 - 102 - 103	
<i>PROFILO SCARICO ACQUE</i>	TGS 105	TGS 106
<i>TAPPO SCARICO ACQUE TGS 107</i>	TAPPO PER TGS 105 - 106	

**TGS 200 - SISTEMA PER PARAPETTI**

	3 METRI	6 METRI
<i>PROFILO A PAVIMENTO</i>	TGS 200	TGS 201
<i>PROFILO FRONTE SOLETTA</i>	TGS 202	TGS 203
<i>TAPPO TGS 204</i>	TAPPO PER PROFILI TGS 200 - 201 - 202 - 203	
<i>PROFILO SCARICO ACQUE</i>	TGS 205	TGS 206
<i>TAPPO SCARICO ACQUE TGS 207</i>	TAPPO PER TGS 205 - 206	

**TGS 300 - SISTEMA PER PARAPETTI AD INCASSO**

	3 METRI	6 METRI
<i>PROFILO AD INCASSO</i>	TGS 300	TGS 301
<i>CARTER INTERNO</i>	TGS 302	TGS 303
<i>CARTER ESTERNO</i>	TGS 304	TGS 305

**TGS 400 - SISTEMA PER PARAPETTI**

	3 METRI	6 METRI
<i>PROFILO A PAVIMENTO</i>	TGS 400	TGS 401
<i>PROFILO FRONTE SOLETTA</i>	TGS 402	TGS 403
<i>TAPPO TGS 404</i>	TAPPO PER PROFILI TGS 400 - 401	
<i>TAPPO FRONTE SOLETTA</i>	TAPPO PER PROFILI TGS 402 - 403	
<i>TAPPO FS 30° TGS 406</i>	TAPPO PER PROFILI TGS 402 - 403 con taglio inclinato 30° uso scale	
<i>PROFILO SCARICO ACQUE</i>	TGS 813	TGS 814
<i>TAPPO SCARICO ACQUE</i>	TAPPO PER TGS 813 - 814	

**TGS 500 - PENSILINA**

	3 METRI	6 METRI
<i>PROFILO PENSILINA</i>	TGS 500	TGS 501
<i>TAPPO TG 702</i>	TAPPO PER PROFILI TGS 500 - 501	

**TGS 600 - SISTEMA PER PARAPETTI - EDILIZIA PUBBLICA**

	3 METRI	6 METRI
<i>PROFILO A PAVIMENTO</i>	TGS 600	TGS 601
<i>PROFILO FRONTE SOLETTA</i>	TGS 602	TGS 603
<i>TAPPO TGS 604</i>	TAPPO PER PROFILI TGS 600 - 601 - 602 - 603	
<i>PROFILO SCARICO ACQUE</i>	TGS 205	TGS 206
<i>TAPPO SCARICO ACQUE TGS 207</i>	TAPPO PER TGS 205 - 206	

**1. Conteggia il profilo in barra**

Esempio: devi realizzare 36 metri lineari di parapetto? Ordina n°6 TGS101

**Bar profile count**

Example: To realize 36 meter of balustrade you may order n°6 TGS101

**2. Abbina i cunei in base al vetro che vuoi montare.**

Si consiglia l'utilizzo di tre cunei al metro (ad esempio per una barra di TGS101, lunga 6 m occorreranno 18 cunei) aiutati con la seguente tabella.

Combine the **wedges** according to the glass you want to mount.

The use of three wedges per meter is recommended Ex: TGS101 is a six meter bar, you may order 18 wedges, use the following matching table.

PROFILI - PROFILES	CUNEI - WEDGES		
	TGS001	TGS002	TGS003
TGS50	TGS50 usa piattelli già inclusi nei profili – locking plates included		
TGS100	/	Vetro - Glass 8+1.52+8	Vetro - Glass 10+1.52+10
TGS200	/	Vetro - Glass 8+1.52+8	Vetro - Glass 10+1.52+10
TGS300	Vetro - Glass 8+1.52+8	Vetro - Glass 10+1.52+10	
TGS400	Vetro - Glass 8+1.52+8	Vetro - Glass 10+1.52+10	Vetro - Glass 12+1.52+12
TGS500	La pensilina utilizza cunei specifici, già forniti con la barra del profilo – wedges are included in the profile bar		
TGS600	/	Vetro - Glass 8+1.52+8	Vetro - Glass 10+1.52+10

**3. Conteggia tappi e altri eventuali accessori**

Count the **caps** and any **other accessories**

**4. Conteggia le guarnizioni, il metraggio è sempre il doppio rispetto ai metri lineari di installazione. Ad esempio per 36 metri lineari di TGS101 considera l'impiego di 72 metri lineari di guarnizione**

Count the **gaskets**, the length is always double compared to the linear meters of installation. For example, for 36 linear meters of TGS101 consider the use of 72 linear meters of gasket

**GUARNIZIONI**

**TGS 000**

Guarnizione a palloncino colore grigio

NON COMPATIBILE CON TGS 400 E VETRO 8+8  
NON NECESSARIA IN TGS 500 POICHÉ GIÀ  
INCLUDE NEL PROFILO



**TG 309**

Guarnizione tradizionale colore grigio e nero





ACCESSORI IN ALLUMINIO  
PER SERRAMENTI, RINGHIERE,  
BALCONI E SCALE



Ed. 2022

**COMPAS SRL**

VIA GOBETTI 21 | 20090 BUCCINASCIO, MILANO  
Tel. +39 02 48843894 | Fax +39 02 48843763

[compas@compas-srl.it](mailto:compas@compas-srl.it)  
[www.compas-srl.it](http://www.compas-srl.it)